



## AAON Touchscreen Controller



## User's Manual

### WARNING

#### QUALIFIED INSTALLER

Improper installation, adjustment, alteration, service or maintenance can cause property damage, personal injury or loss of life. Installation and service must be performed by a trained, qualified installer. A copy of this manual should be kept with the unit.



## Table of Contents

Index of Tables .....	5
AAON® Touchscreen Mini Controller Features and Options .....	6
Safety .....	7
Installation.....	9
AAON Touch Screen Mini Controller Specifications .....	9
Controller Specifications .....	13
Sensor Specifications .....	14
Unit Controller Wiring Schematic .....	28
Startup.....	33
Home Screen Navigation .....	33
Controller Setup.....	35
Unit Configuration .....	35
Application Configuration 1 .....	37
Application Configuration 2 .....	38
Cooling Configuration .....	39
Heating Configuration .....	40
Condenser Fan Configuration.....	41
Water-Cooled Condenser Configuration .....	42
Outside Air Control Configuration.....	43
Heat Pump Configuration .....	44
Dehumidification Configuration.....	45
Exhaust Fan Configuration .....	46
Network Configuration .....	47
Security Configuration.....	48
System Information.....	48
Supply Fan Configuration.....	49
Manual System Tests .....	50
Setpoint Adjustment.....	51
Cooling Setpoints.....	51
Heating Setpoints .....	52
Dehumidification Setpoints .....	53
Economizer Setpoints .....	54
Supply Fan Setpoints .....	55
Exhaust Fan Setpoints.....	55
Condenser Setpoints .....	56
Heat Pump Setpoints.....	57
Outside Air Flow Monitoring Setpoints .....	58
Heat Wheel Setpoints.....	58
Sensor Calibration.....	58
Inputs .....	59
Outputs.....	60
General Alarms .....	61
Shutdown Alarms .....	62
Schedule Setup.....	63

Sequences of Operation .....	65
Cooling Operation.....	65
Heating Operation.....	68
Dehumidification Operation .....	70
Occupancy/Supply Fan Operation .....	73
Additional Feature Sequences .....	74
Network Points List .....	78
Maintenance and Support .....	82
Replacement Parts.....	82
Glossary .....	83
AAON Touchscreen Mini Controller Startup Form .....	84
Maintenance Log .....	85
Literature Change History.....	87

V71810 · Rev. A · 190702



## Index of Figures

Figures	
Figure 1 - Backplate Terminal Locations .....	10
Figure 2 - Backplate Terminals and Field Wiring to the Unit .....	11
Figure 3 - Unit Controller located in the HVAC equipment .....	13
Figure 4 - Space Mounted Touchscreen Controller .....	13
Figure 5 - Suction Pressure Transducer .....	14
Figure 6 - Discharge Pressure Transducer .....	15
Figure 7 - Mixed Air Temperature Sensor .....	16
Figure 8 - Return and Supply Air Temperature Sensor .....	17
Figure 9 - Outside Air Temperature Sensor .....	18
Figure 10 - Return Air Temperature and Humidity Combo Sensor .....	19
Figure 11 - Return Air Temperature and Humidity Combo Sensor .....	20
Figure 12 - Building Static Pressure Transducer .....	21
Figure 13 - Return Air CO <sub>2</sub> Sensor .....	22
Figure 14 - Discharge Line Temperature Sensor .....	23
Figure 15 - Air Flow Switch .....	24
Figure 16 - Water Flow Switch .....	25
Figure 17 - Clogged Filter Switch .....	26
Figure 18 - Duct Static Pressure Sensor .....	27
Figure 19 - AAON Touchscreen Mini Controller .....	34
Figure 20 - Home Screen Icons .....	34
Figure 21 - Space-Supply Air Cooling Reset Example .....	67
Figure 22 - Space-Supply Air Heating Reset Example .....	70

## Index of Tables

Table 1 - Control Wiring .....	11
Table 2 - Glycol Freeze Protection .....	42
Table 3 - BACnet Points List (Analog Values 1) .....	78
Table 4 - BACnet Points List (Analog Values 2) .....	79
Table 5 - BACnet Points List (Analog Values 3) .....	80
Table 6 - BACnet Points List (Binary/Relay Values 1) .....	80
Table 7 - BACnet Points List (Binary/Relay Values 2) .....	81

## **AAON® Touchscreen Controller Features and Options**

- User-Friendly, High-Contrast, 4.3” Touch Screen Interface
- Temperature and Humidity Control
- Simple Field Wiring - Five Wires Between Unit and Touchscreen Controller
- Up To Two Compressors
- On/Off, Two-Step, and Variable Capacity Compressor Control
- Single or Dual Variable Capacity Scroll Compressor Control
- Selectable Mode Enable Sensors
- Space-Supply Reset Functions
- Outside Air Flow Monitoring
- Constant Air Volume, Variable Air Volume, Single Zone VAV, and Makeup Air Control
- Hydronic Air Handling Unit
- Chilled Water and Hot Water Fully Modulating Valve Control
- Daily and Weekday/Weekend Scheduling
- Admin, Operator, and User Security Profiles
- Alarms
- BACnet MS/TP Network Connection (RS-485)
- Modbus RTU Network Connection (RS-485)
- Up to Four Stages of Gas or Electric Heat
- Modulating Gas/SCR Electric Heat
- Up to Four Stages of Auxiliary/Emergency Heat
- Modulating SCR Electric Preheat

### Options Available

- Sensible, Enthalpy, or Comparative Enthalpy Controlled Fully Modulating Economizer
- CO<sub>2</sub> Override
- Outside Airflow Monitoring Control
- Condenser Fan Head Pressure Control
- Water-Cooled Condenser Control
- Exhaust Fan Building Pressure Control
- Energy Recovery Wheel Control
- Space Humidity Control
- Outside Air Humidity Control
- Fan Status
- Clogged Filter Switch

## Safety

Attention should be paid to the following statements:

**NOTE** - Notes are intended to clarify the unit installation, operation and maintenance.

**⚠ CAUTION** - Caution statements are given to prevent actions that may result in equipment damage, property damage, or personal injury.

**⚠ WARNING** - Warning statements are given to prevent actions that could result in equipment damage, property damage, personal injury or death.

**⚠ DANGER** - Danger statements are given to prevent actions that will result in equipment damage, property damage, severe personal injury or death.

### **⚠ WARNING**

#### **ELECTRIC SHOCK, FIRE OR EXPLOSION HAZARD**

Failure to follow safety warnings exactly could result in dangerous operation, serious injury, death or property damage.

Improper servicing of HVAC equipment could result in dangerous operation, serious injury, death or property damage.

- Before servicing, disconnect all electrical power to the equipment. More than one disconnect may be provided.
- When servicing controls, label all wires prior to disconnecting. Reconnect wires correctly.
- Verify proper operation after servicing. Secure all doors with key-lock or nut and bolt.

### **⚠ WARNING**

Electric shock hazard. Before servicing, disconnect all electrical power to the equipment, including remote disconnects, to avoid shock hazard or injury from rotating parts. Follow proper Lockout-Tagout procedures.

### **⚠ WARNING**

#### **GROUNDING REQUIRED**

All field installed wiring must be completed by qualified personnel. Field installed wiring must comply with NEC/CEC, local and state electrical code requirements. Failure to follow code requirements could result in serious injury or death. Provide proper unit ground in accordance with these code requirements.

 **WARNING**

During installation, testing, servicing and troubleshooting of the equipment it may be necessary to work with live electrical components. Only a qualified licensed electrician or individual properly trained in handling live electrical components shall perform these tasks.

Standard NFPA-70E, an OSHA regulation requiring an Arc Flash Boundary to be field established and marked for identification of where appropriate Personal Protective Equipment (PPE) be worn, should be followed.

1. READ THE ENTIRE USER'S MANUAL. OTHER IMPORTANT SAFETY PRECAUTIONS ARE PROVIDED THROUGHOUT THIS MANUAL.
2. Keep this manual and all literature safeguarded near the equipment.

## Installation

The AAON Touch Screen Controller has been designed for simple HVAC system control.

 <b>WARNING</b>
Improper installation, adjustment, alteration, service or maintenance can cause property damage, personal injury or loss of life. Installation and service must be performed by a trained, qualified installer. A copy of this manual should be kept with the unit.

### Codes and Ordinances

HVAC system should be sized in accordance with the American Society of Heating, Refrigeration and Air Conditioning Engineers Handbook.

Installation of equipment must conform to the ICC standards of the International Mechanical Code, the International Building Code, Installation of Air Conditioning and Ventilating Systems Standard, NFPA 90A, and local building, plumbing and waste water codes. All appliances must be electrically grounded in accordance with local codes, or in the absence of local codes, the current National Electric Code, ANSI/NFPA 70 or the current Canadian Electrical Code CSA C22.1.

### Receiving Unit

When received, the controller should be located and checked for damage that might have occurred in transit. It should be stored in a safe place until installation.

## AAON Touch Screen Mini Controller Specifications

Touchscreen Controller -  
AAON Part Number: V62130  
Unit Controller -  
AAON Part Number: V62370

*Supply Voltage:* 24 VAC (+15%/-10%), Class-2

*Supply Power:* 10 VA

*Connections:* Wire clamp type terminal blocks; 14-22 AWG, copper; 4 pin EIA-485

*Outputs:* Analog outputs produce 0-10 VDC, 5 mA maximum

*Relay Outputs:* Maximum output current for individual relays is 5A @ 24 VAC. 10A maximum total for all relays. Relays are Normally Open, Single Pole Single Throw, Form A

*Inputs:*  
Resistive Inputs: 10K Type 3 Thermistor  
Voltage Inputs: 500 uA/0-10 VDC  
Binary Inputs: 15 mA/24 VAC

*Display:* 480 x 272 pixel dot matrix LCD

*Case Material:*  
White flame retardant ABS plastic

*Dimensions:*  
4 x 5.25 x 1.2 inches (H x W x D)

*Weight:*  
.4268 lbs (6.83 oz)

*Approvals:*  
UL 916 Energy Management Equipment  
FCC Class B, Part 15, Subpart B

*Temperature Sensor:*

Solid State

Accuracy:

+/-0.9°F (+/-0.5°C) from 0-70°C

Resolution:

+/- 0.1°F (+/-0.2°C)

Operating Range:

-4-158°F (-20-70°C)

Response Time:

2-30 seconds

*Humidity Readings*

Range:

0-95% RH

Accuracy:@ 30°C

+/-3% RH (20-80% RH)

*Environmental Limits*

Operating:

-4-158°F (-20-70°C)

Storage Temperature:

-22-176°F (-30-80°C)

Humidity:

0-95% RH non-condensing

**! WARNING**

Disconnect all electrical power sources before servicing the unit. More than one power source may be provided. Failure to do so may result in injury or death from electrical shock or entanglement in moving parts.

**Mounting the Controller**

For optimum performance controller should be mounted on an interior wall 4-5 feet above the floor away from heat sources, sunlight, windows, air vents and air circulation obstructions.

1. Complete rough-in wiring at each location prior to controller installation.
2. Tabs must be pulled out to remove the front display from the backplate.

3. Route wiring through the backplate.
4. Fasten the backplate directly to a vertical 2x4 inch wall handy box.
5. Make the appropriate connections to the terminal block.
6. Snap controller cover over the backplate using the tabs on the top and bottom while being careful not to pinch or dislodge any wiring.

**! CAUTION**

Prevent mounting screw heads from touching the circuit board in the controller Use only the mounting screws provided with the controller. Using screws other than the type supplied may damage the controller.

**Electrical**

Connection terminations are made to the main terminal block of the controller and the HVAC equipment.

A complete set of unit specific wiring diagrams, showing factory and field wiring are laminated in plastic and located inside the controls compartment door of the AAON HVAC equipment.

**AAON Touchscreen Mini Controller Backplate Layout**

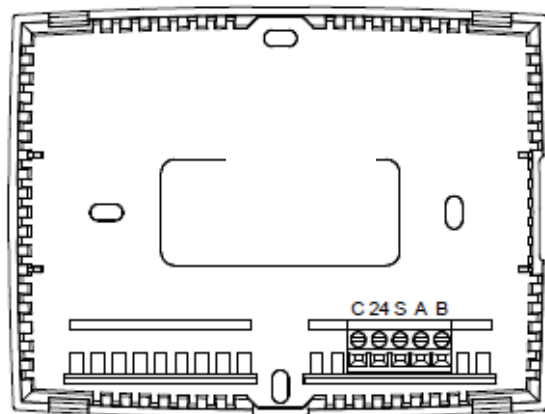

Figure 1 - Backplate Terminal Locations

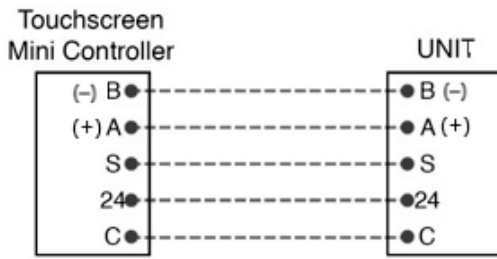

Figure 2 - Backplate Terminals and Field Wiring to the Unit

Touchscreen Mini Controller

C = Common

24 = 24 VAC

S = Shield

A (+) = Communication

B (-) = Communication

### Control Wiring

Control wiring size must be large enough to prevent excess voltage drop and ensure proper operation. Control voltage returning from controller circuit must be a minimum of 21 VAC. If the voltage at the connectors is less than 21 VAC, isolation relays must be installed. If under external control 21 VAC must be field verified. To assure proper wiring use the following table to determine the allowable wiring distances.

Table 1 - Control Wiring

Wire Size (Stranded) - Copper Conductors Only	Total Wire Distance Allowable	Individual Wire Distance Allowable
20 AWG	200 ft	40 ft
18 AWG	350 ft	70 ft
16 AWG	500 ft	100 ft
14 AWG	750 ft	150 ft
12 AWG	1250 ft	250 ft

Total Wire Distance Allowable =  
 (Quantity of Control Wires) x  
 (Control Wire Distance)

Take the total wire distance allowable and divide by the quantity of wires to be

connected. This indicates the distance allowable for that size wire. The wiring to the unit must not exceed the total wire distance allowable. Field wiring between the unit and space controller will always require 5 wires.

All external devices must be powered via a separate external power supply.

Example:

A total of 5 wires must be pulled 75 ft to space controller from the unit. What size wire should be used?

According to Table 1, 16 AWG allows for 100 ft and 18 AWG allows for 70 ft. Thus, 16 AWG wire should be used.

### BACnet MS/TP EIA-485 Wiring

Connect the A(+) terminals in parallel with all other A(+) terminals on the network and the B(-) terminals in parallel with all other B(-) terminals. Connect the shields of the cable together at each device using a wire nut. Connect the cable shield to a good earth ground at one end only.

Controllers on the physical ends of the EIA-485 wiring segment must have end-of-line termination.

**! CAUTION**

Relays are for Class-2 (24 VAC) only. Do not connect line voltage to the relays.

**! CAUTION**

Do not mistakenly connect 24 VAC to an analog output ground. This is not the same as a relay's switched common. See the backplate terminal label for the correct terminal.

The Touchscreen Mini controller requires a 24 VAC power source. AAON requires

powering the Touchscreen Controller with the transformer in the HVAC unit along with the communication wiring from the Unit Controller to the Touchscreen Controller in the space.



# Controller Specifications

Unit Controller  
AAON Part Number: V62370

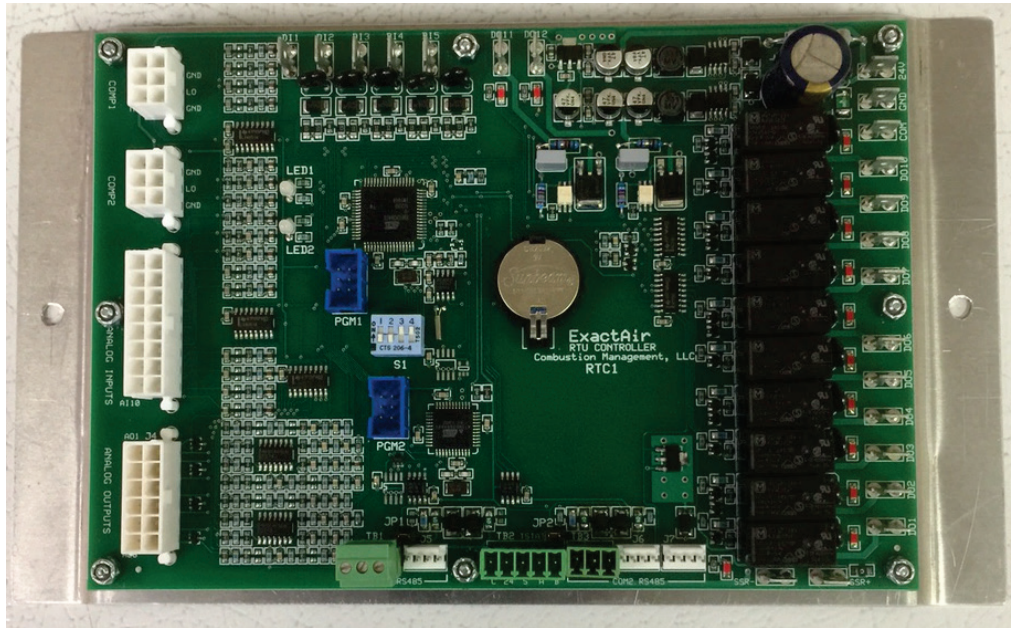

Figure 3 - Unit Controller located in the HVAC equipment

CR2032 3V battery on the controller is used for clock.

Space Controller  
AAON Part Number: V62130



Figure 4 - Space Mounted Touchscreen Controller

## Sensor Specifications

### Refrigerant Pressure Sensors

Suction Pressure Transducer

Circuit 1

Terminal: LPRS1

Circuit 2

Terminal: LPRS2

AAON Part Number: V38400

Description: 1/4" SAE Female Flare fitting and Schrader valve. The pressure transducer has an output voltage of 0.5-4.5 VDC (ratio metric) and is also overvoltage protected in both positive and reverse polarity. Sensor range is 0-500 psig.



Figure 5 - Suction Pressure Transducer

Discharge Pressure Transducer

Circuit 1

Terminal: HPRS1

Circuit 2

Terminal: HPRS2

AAON Part Number: V38410

Description: 1/4" SAE Female Flare fitting and Schrader Valve. The pressure transducer has an output voltage of 0.5 to 4.5 VDC (ratio metric) and is also overvoltage protected in both positive and reverse polarity. Sensor range is 0-667 psig.



Figure 6 - Discharge Pressure Transducer

## Temperature Sensors

Mixed Air Temperature Sensor  
Terminal: AI1

AAON Part Numbers:

R38420 (8')

R38410 (12')

R38400 (24')

Description:

Temperature sensor uses a 10K Ohm thermistor. This sensor comes encased in a 24', 12', or 8' long bendable copper sheath.

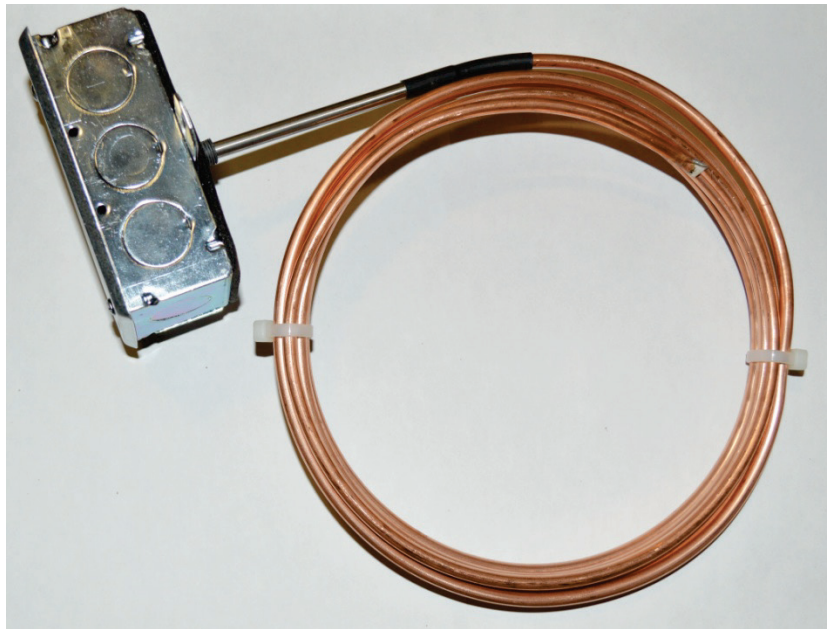

Figure 7 - Mixed Air Temperature Sensor

Return Air Temperature Sensor  
Terminal: AI2

Supply Air Temperature Sensor  
Terminal: AI3

AAON Part Number: R38180

Description: Temperature sensor uses a 10K Ohm thermistor. Duct mount configuration with an 8" stainless steel probe. The unit should be mounted using the integral galvanized mounting flange. Supply air temperature sensor must be field installed in the supply ductwork 6-8 feet downstream from the unit to get an accurate reading.

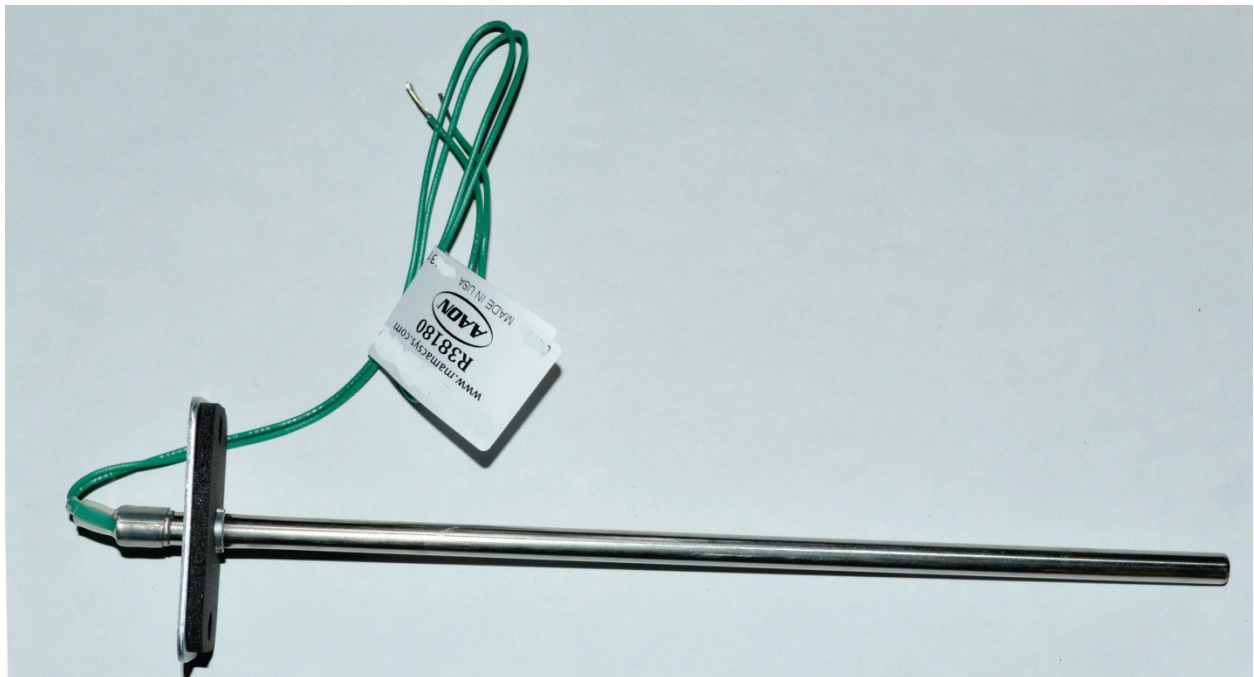

Figure 8 - Return and Supply Air Temperature Sensor



Outside Air Temperature Sensor  
Terminal: AI4

AAON Part Number: R38190

Description: The temperature sensor uses a 10K Ohm (Type III) thermistor sensor. Weather proof configuration with a plastic tube. The unit should be mounted using the tabs on the enclosure with the plastic tube facing down.



Figure 9 - Outside Air Temperature Sensor

## Temperature and Humidity Sensors

Return Air Temperature and Humidity Combo Sensor  
Terminal: AI5

AAON Part Number: R38540



Figure 10 - Return Air Temperature and Humidity Combo Sensor

Outside Air Temperature and Humidity Combo Sensor  
Terminal: AI6

AAON Part Number: R38530



Figure 11 - Return Air Temperature and Humidity Combo Sensor



## Additional Sensors

Building Static Pressure Sensor

Terminal: AI10

AAON Part Number: R19440

Description: (0-10 VDC) Pressure Transmitter



Figure 12 - Building Static Pressure Transducer

Return Air CO<sub>2</sub> Sensor  
Terminal: AI7  
AAON Part Number: V57760



Figure 13 - Return Air CO<sub>2</sub> Sensor

Discharge Line Temperature Sensor

Terminal: TEMP1

Terminal: TEMP2

AAON Part Numbers:

R57800 (1/2 in. Tube)

R42680 (7/8 in. Tube)



Figure 14 - Discharge Line Temperature Sensor

Air Flow Proving Switch  
Terminal" DI2  
AAON Part Number: R62330



Figure 15 - Air Flow Switch

Water Flow Switch  
Terminal: DI4  
AAON Part Number: R70490



Figure 16 - Water Flow Switch



Clogged Filter Switch  
Terminal: DI5  
AAON Part Number: R64580

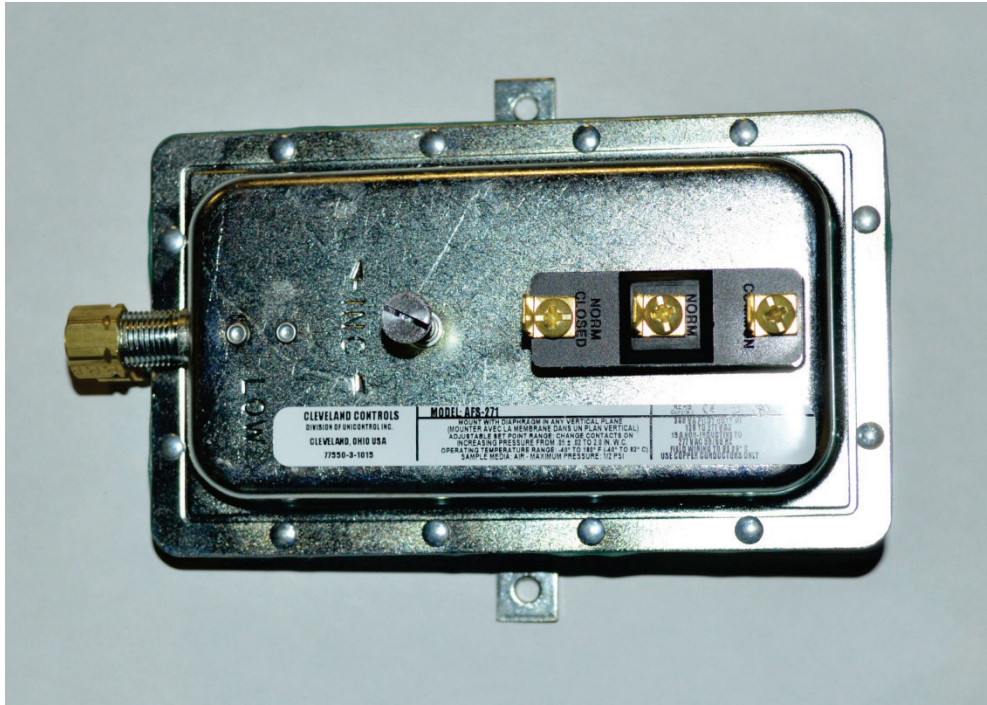

Figure 17 - Clogged Filter Switch

Duct Static Pressure Sensor  
Terminal: A19  
AAON Part Number: R17050

Description: (0-10VDC)

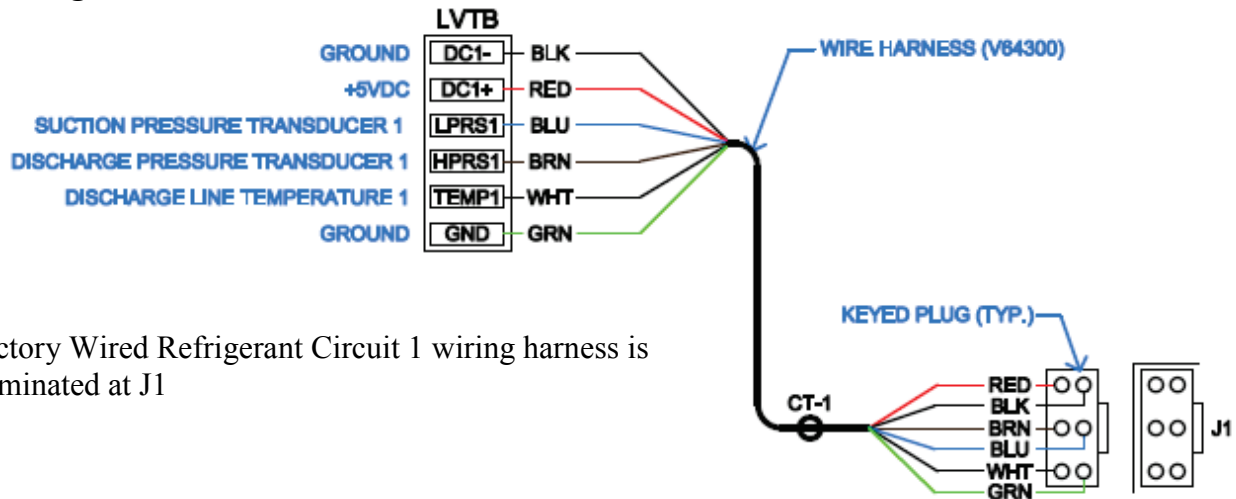

Figure 18 - Duct Static Pressure Sensor





### Refrigerant Circuit 1 Terminals



Factory Wired Refrigerant Circuit 1 wiring harness is terminated at J1

### Refrigerant Circuit 2 Terminals

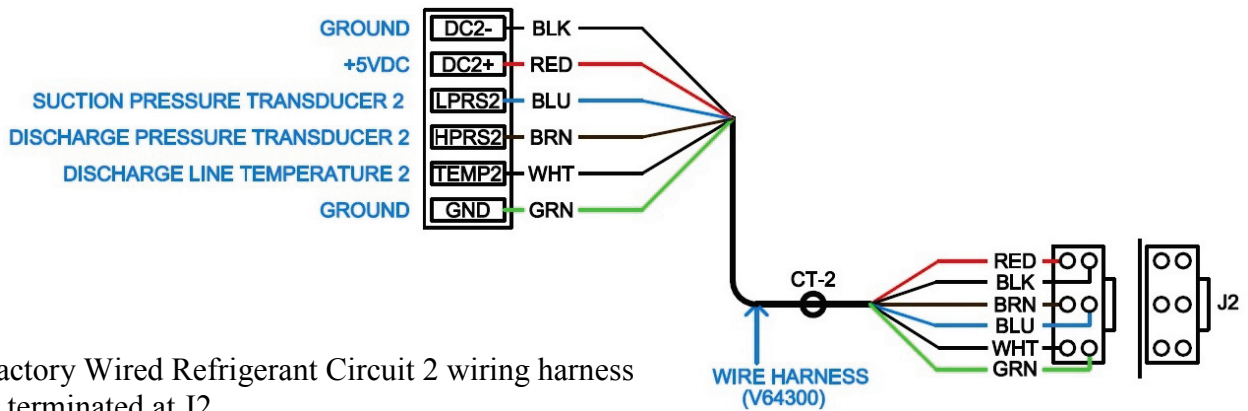

Factory Wired Refrigerant Circuit 2 wiring harness is terminated at J2

## Analog Inputs Terminal

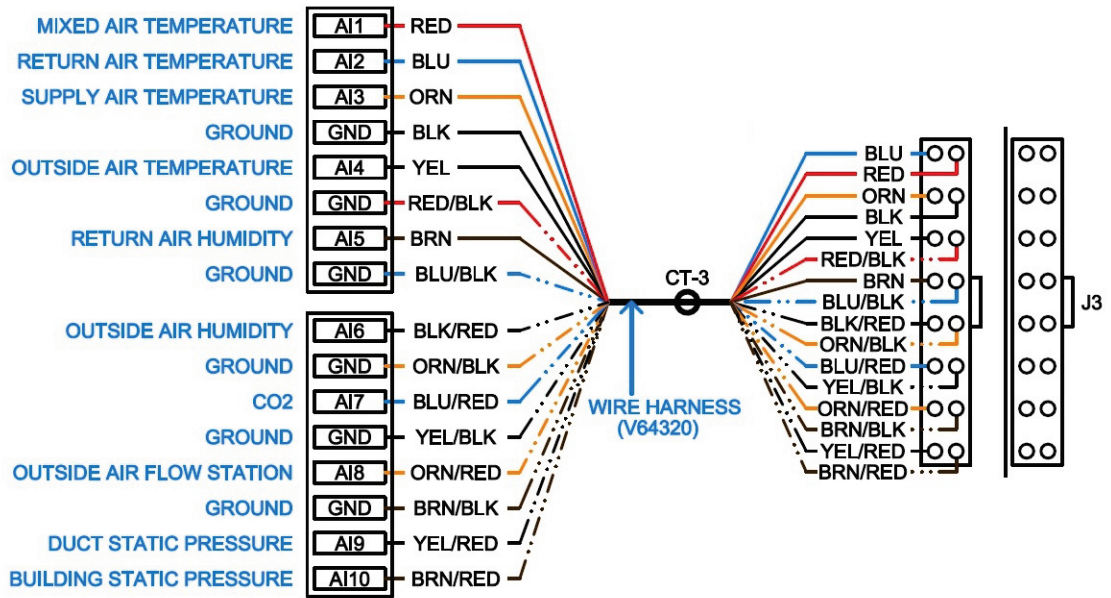

Factory Wired Analog Inputs wiring harness is terminated at J3

## Analog Outputs Terminal

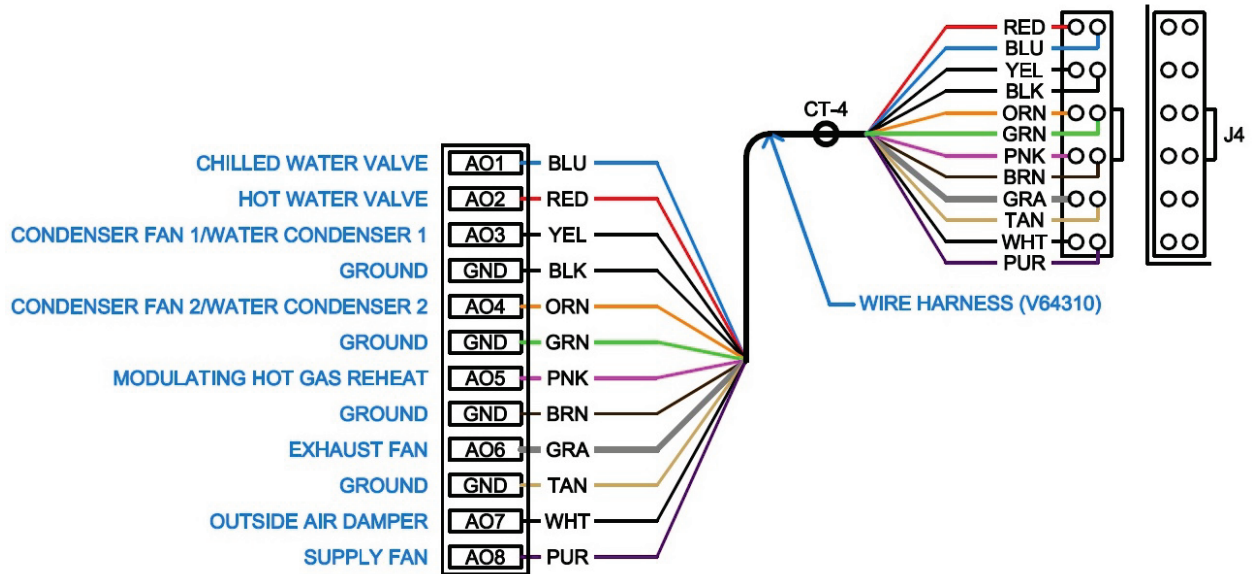

Analog Outputs Wiring Harness is located at J4

## Communication Terminals

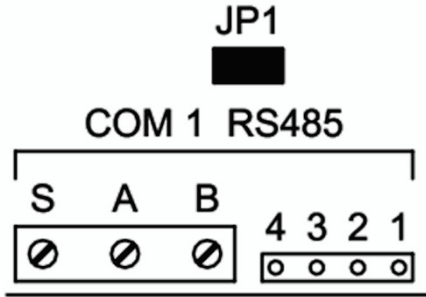

Field Wired Com 1 port is used for Building Management System Communications

## Touchscreen Mini Controller Terminal

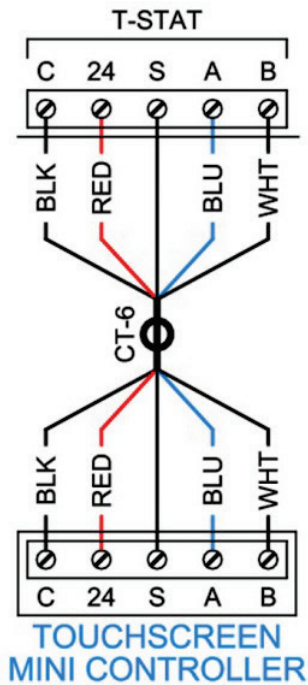

Field wired connection to the space mounted Touchscreen Mini Controller

## Relay Outputs Terminal

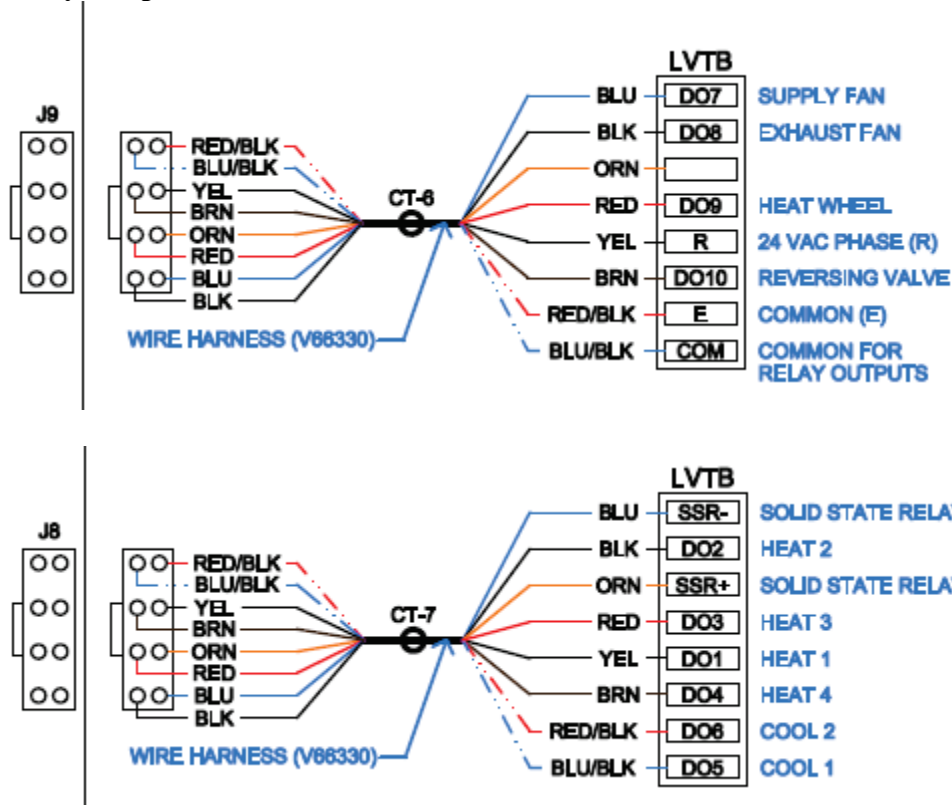

Factory Wired Relay Outputs Wiring Harnesses are terminated at J8 and J9

## Binary Inputs and Digital Outputs

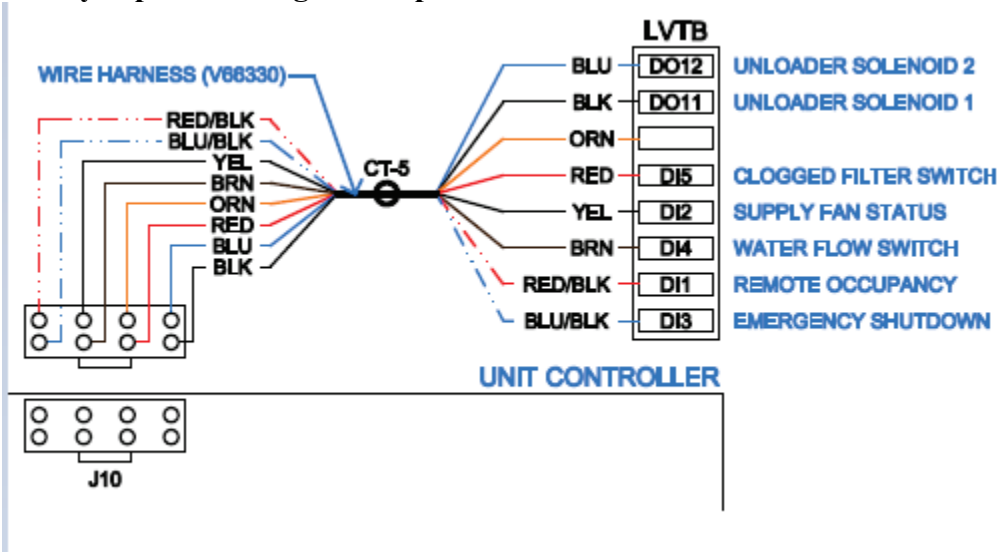

Factory Wired Binary Inputs and Digital Outputs Wiring Harness is terminated at J10

## Startup

### **WARNING**

Improper installation, adjustment, alteration, service or maintenance can cause property damage, personal injury or loss of life. Installation and service must be performed by a qualified installer. A copy of this IOM should be kept with the unit.

## Home Screen Navigation

### General

**Fan** - Indicates supply fan operation. Animated icon indicates the fan is operating. Motionless icon indicates fan is not operating.

**Mode** - Indicates the current Mode of Operation: Cooling, Heating, Dehumidification, Ventilation, Economizer, or Off.

**Occupied/Unoccupied** - Indicates the current occupancy status. Black icon indicates Occupied and gray icon indicates Unoccupied. During Unoccupied Mode if the icon is pressed the controller will override into Occupied Mode for 30 minutes.

**Menu** - Touch to open up Setpoints, I/O Alarms, Schedule, and Setup Menus

**Temperature/Humidity** - Space temperature, space relative humidity, supply air temperature, return air temperature, mixed air temperature, outside air temperature are displayed

**Alarm** - Yellow bell indicates a General Alarm and red bell indicates a Shutdown Alarm.

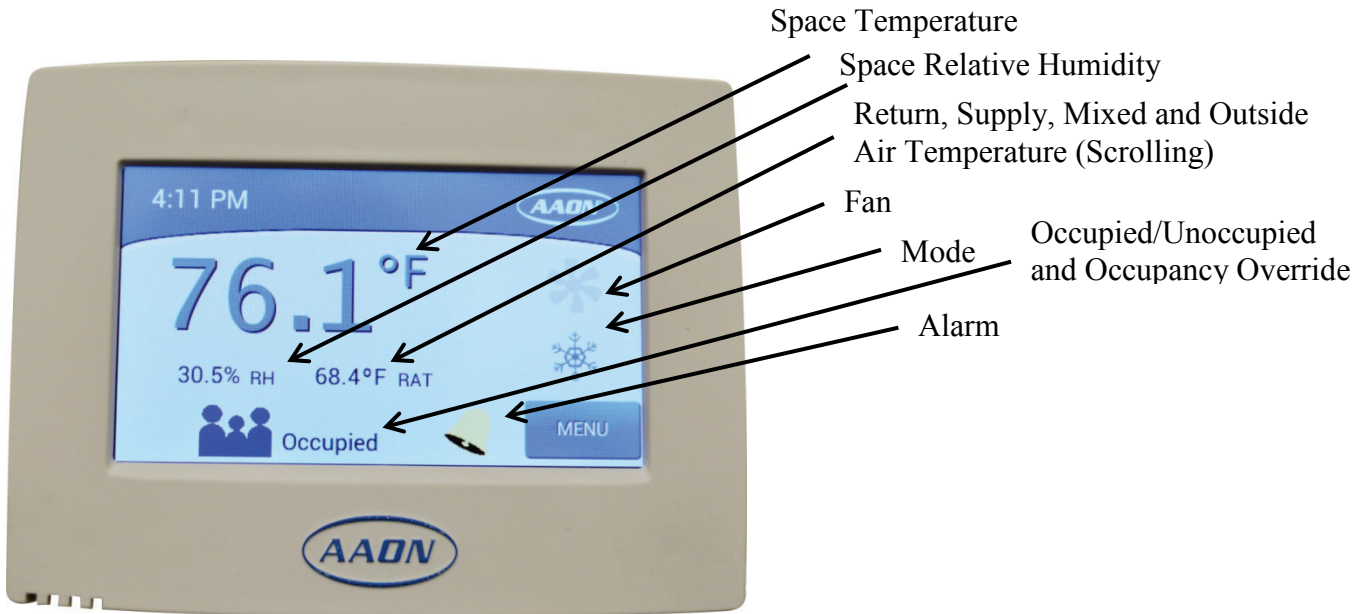

Figure 19 - AAON Touchscreen Mini Controller

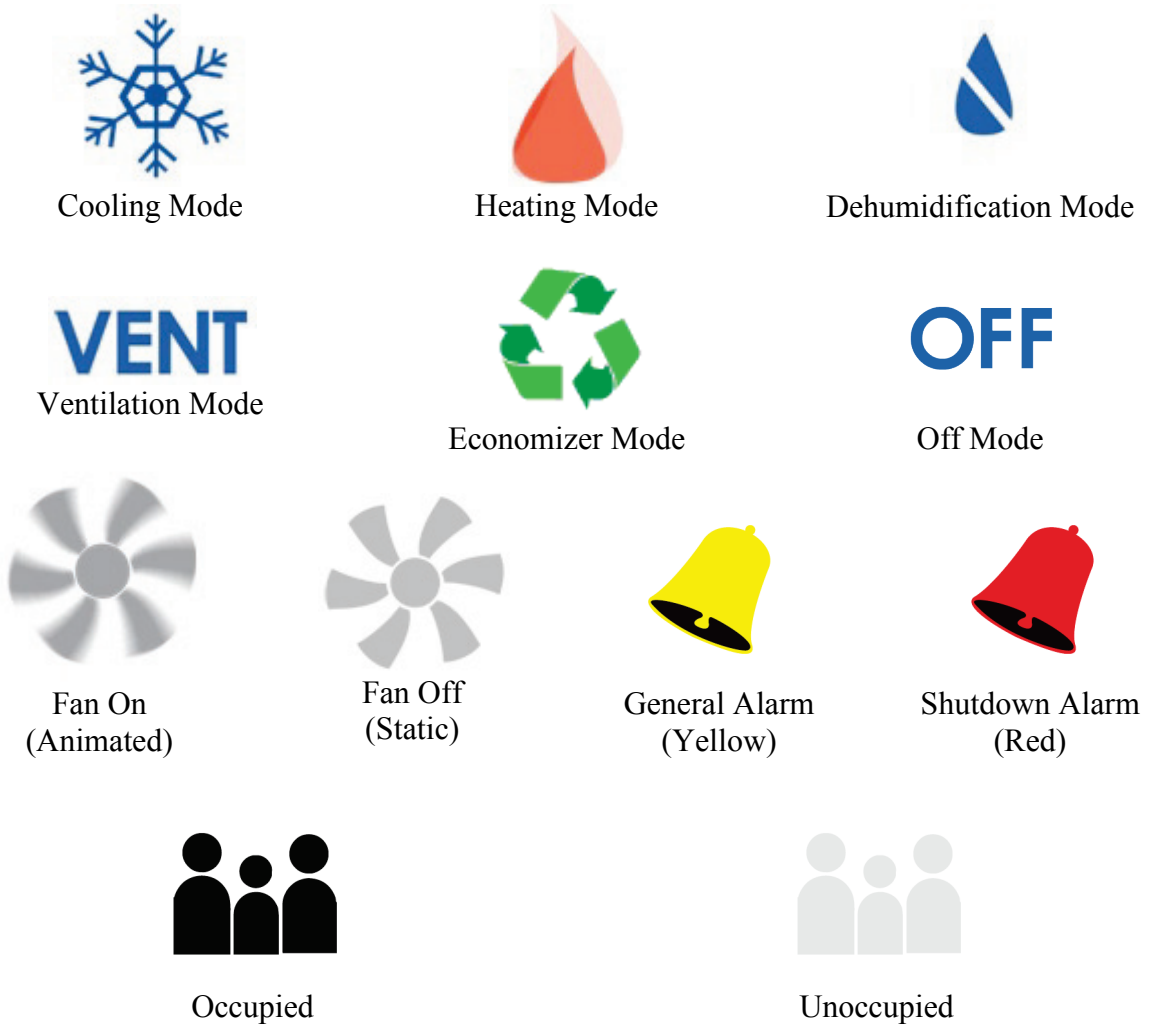

Figure 20 - Home Screen Icons



## Controller Setup

### Unit Configuration



**Home Screen:** This is the main home screen of the Touchscreen Mini Controller interface.

*Clicking on Menu will navigate to the Menu screen.*

*During Unoccupied Mode if the Unoccupied icon is pressed the controller will override into Occupied Mode for 30 minutes.*



**Menu Screen:** This screen gives access to Setpoints, Inputs/Outputs/Alarms, Schedule, and Setup. A password will be required to access these screens.

#### ***Menu → Setup***

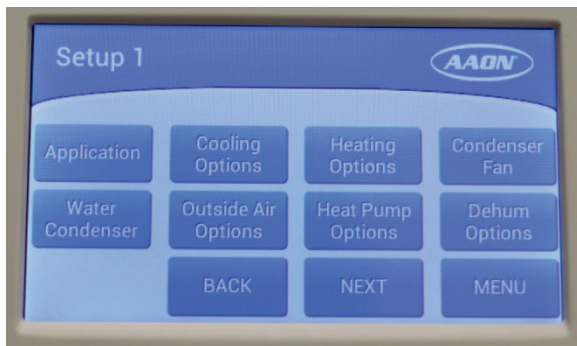

**Setup Screen 1:** This screen gives access to Application, Cooling Options, Heating Options, Condenser Fan Options, Water-Cooled Condenser Options, Outside Air Options, Heat Pump Options, and Dehumidification Options.

*Clicking on Next will navigate to the second setup screen.*

#### ***Menu → Setup → Next***



**Setup Screen 2:** This screen gives access to Exhaust Fan Options, Network Configuration, Security Settings, System Information, Supply Fan Options, and Manual Test.

*Clicking on Menu will navigate back to the Menu screen.*

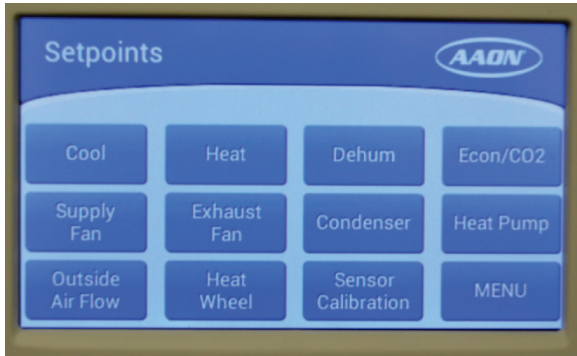

**Menu → Setpoints**

**Setpoints Screen:** This screen gives access to Cooling, Heating, Dehumidification, Economizer, CO<sub>2</sub>, Supply Fan, Exhaust Fan, Condenser, Heat Pump, and Outside Airflow, Energy Recovery Wheel Setpoints, and Sensor Calibration.



**Menu → Schedule**

**Schedule Screen:** This screen gives access to the Occupied/Unoccupied schedule and setting the time and date.



**Menu → Schedule**

**I/O - Alarms Screen:** This screen gives access to viewing inputs, outputs, general alarms, and shutdown alarms.

*Clicking on Menu from any of these screens will navigate back to the Menu screen.*



## Application Configuration 1

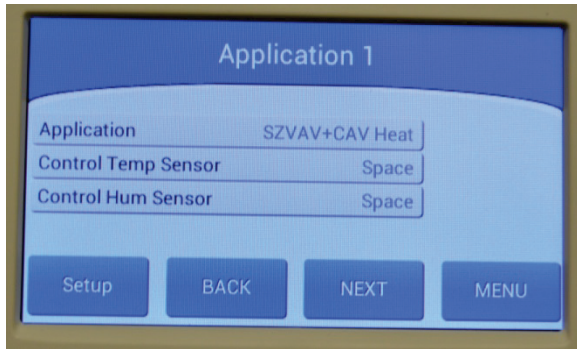

**Menu** → **Setup** → **Application**

**Application =**

**CAV:** Constant Air Volume application

**MUA:** Makeup Air application

**SZVAV + CAV Heat:** Single Zone VAV application with Single Zone VAV Cooling and CAV Heating

**VAV:** Variable Air Volume application with VAV Cooling

**Control Temp Sensor =**

**Space:** Heating/Cooling modes of operation based on Space Temperature

**Return:** Heating/Cooling modes of operation based on Return Air Temperature

**Outside/Space:** Heating/Cooling modes of operation in occupied mode based on Outside Air Temperature. Heating/Cooling modes of operation in unoccupied mode based on Space Temperature.

**Outside/Return:** Heating/Cooling modes of operation during occupied mode based on Outside Air Temperature. Heating/Cooling modes of operation in unoccupied mode based on Return Air Temperature.

**Avg Space & Return:** Heating/Cooling modes of operation based on average of Space Temperature and Return Air Temperature

**Control Hum Sensor =**

**Space:** Dehumidification mode of operation based on Space Relative Humidity

**Return:** Dehumidification mode of operation based on Return Relative Humidity

**Outside/Space:** Occupied Dehumidification mode of operation based on Outside Relative Humidity. Unoccupied Dehumidification mode of operation based on Space Relative Humidity

**Outside/Return:** Occupied Dehumidification mode of operation based on Outside Relative Humidity. Unoccupied Dehumidification mode of operation based on Return Relative Humidity

*For VAV Application, Control Temp Sensor does not apply. During occupied mode, the system will always be in the Cooling or Dehumidification mode, except during Morning Warm-Up or Cool-Down.*

## Application Configuration 2



*Menu → Setup → Application → Next*

### **Return Damper =**

**Yes:** Return Air Damper/Economizer Control

**No:** No Motorized Return Air Damper or Economizer

### **Unoccupied Mode =**

**On:** Unoccupied and Occupied Modes based on the Schedule, Network, or Remote Occupancy. During Unoccupied Mode unit will cycle to control to Unoccupied setpoints.

**Off:** Unit will always be off during Unoccupied Mode.

### **SAT Setpoints =**

**Fixed:** No supply air temperature reset

**Reset:** Reset available for supply air temperature setpoints. See reset sequence in the sequence of operation section.

## Cooling Configuration

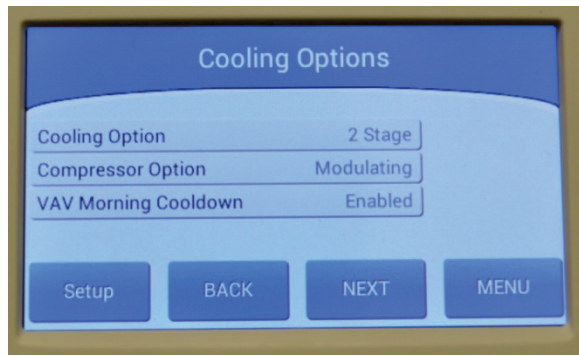

*Menu → Setup → Cooling Options*

### **Cooling Option =**

**No Cool:** No cooling

**1 Stage:** This Cooling option will operate 1 stage of cooling. Select with single compressor units.

**2 Stage:** This Cooling option will operate 2 stages of cooling. Select with two compressor units.

**Chilled Water 0-10V:** Modulating Chilled Water Coil Valve with a 0-10 VDC output signal.

**Chilled Water 2-10V:** Modulating Chilled Water Coil Valve with a 2-10 VDC output signal.

### **Compressor Option:**

**On-Off:** 1 or 2 On/Off Compressors

**Modulating:** 1 or 2 Variable Capacity Compressors.

**Mod/On-Off:** 1 On/Off Compressor and 1 Variable Capacity Compressor

**2-Step:** 1 or 2 Two-Step Compressors

*Compressor option does not apply when Cooling Option = No Cool or Chilled Water*

### **VAV Morning Cool-Down = Enable/Disable**

Only for VAV applications. This enables the morning cool-down mode of operation. Return air temperature sensor required.

## Heating Configuration

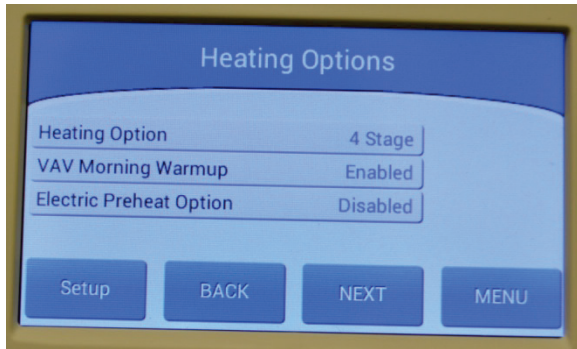

**Menu** → **Setup** → **Heating Options**

**Heating Option =**

**None:** No Heating

**1 Stage:** 1 stage of heating

**2 Stage:** 2 stages of heating

**3 Stage:** 3 stages of heating

**4 Stage:** 4 stages of heating

*With SCR controlled modulating electric heat, select the number of on/off heat stages shown on the unit wiring diagram.*

**Mod Gas:** This Heating option will operate modulating gas heating

**Hot Water 0-10:** Modulating Hot Water Coil Valve with a 0-10 VDC output signal.

**Hot Water 2-10:** Modulating Hot Water Coil Valve with a 2-10 VDC output signal.

**VAV Morning Warm-Up =**

**Enable/Disable**

Only for VAV applications. This enables the morning warm-up mode of operation. Return air temperature sensor required.

**Electric Preheat Option =**

**Enable/Disable**

This enables electric preheat control.

## Condenser Fan Configuration



**Menu** → **Setup** → **Condenser Fan**

### **Condenser Fan =**

**None:** No condenser fans. This includes a water-cooled condenser or chiller water cooling systems.

**On/Off:** Condenser fans will turn on and off with the compressors.

**Head Pressure Control:** Condenser fan speed will be based on discharge pressure.

### **Fan Configuration =**

**Combined:** This Fan Configuration will operate all of the Condenser Fans at the same speed.

**Split:** This Fan Configuration will operate the Condenser Fans based on the corresponding refrigeration circuit. Use with two circuit systems with a split condenser.

*This option does not apply when Condenser Fan Option = None.*

### **Fan Control =**

**On-Off:** This Fan Configuration will operate all of the Condenser Fans at full speed.

**Modulating:** This Fan Configuration will operate the Condenser Fans based on the corresponding refrigeration circuit discharge pressure.

*This option does not apply when Condenser Fan Option = None.*

## Water-Cooled Condenser Configuration

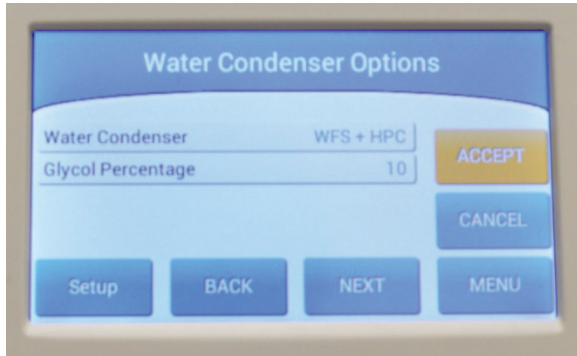

*Menu → Setup → Water Condenser*

**Water Condenser =**

**None:** No Water-Cooled Condenser. This includes an air-cooled condenser or chilled water cooling systems.

**Water Flow Switch:** This Water-Cooled Condenser Option will operate the compressors only if the water flow switch shows water flow.

**Head Pressure Control:** This Water-Cooled Condenser Option will operate the condenser water valve based on discharge pressure in Cooling Mode.

**WFS + HPC:** This Water-Cooled Condenser Option will operate the compressors only if the water flow switch shows water flow and will operate the condenser water valve based on discharge pressure in Cooling Mode.

**Glycol Percentage =** Percentage glycol in the system. See Glycol Freeze Protection table.

*This option does not apply when Water Condenser = None.*

Table 2 - Glycol Freeze Protection

R-410A - % Glycol	0%	5%	10%	15%	20%	25%	30%	35%	40%
Heat Low Suction	100 psig	93 psig	87 psig	82 psig	75 psig	65 psig	58 psig	49 psig	45 psig
Low Leaving Fluid Temp	37°F	34°F	30°F	27°F	20°F	15°F	9°F	2°F	0°F



## Outside Air Control Configuration

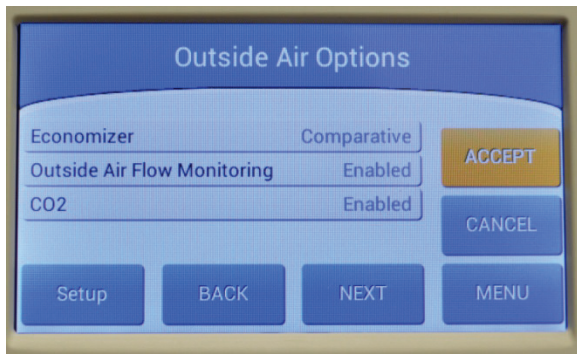

*Menu → Setup → Outside Air Options*

**Economizer =**

**None:** No Economizer

**Sensible:** This Economizer Option will operate the economizer based on outside air temperature.

**Enthalpy:** This Economizer Option will operate the economizer based on outside air enthalpy. Outside air temperature and humidity combo sensor required.

**Comparative:** This Economizer Option will operate the Economizer based on comparative enthalpy of outside and return air. Return air temperature and humidity combo sensor required.

**Outside Air Flow Monitoring =**

**Enable/None:** This will control the economizer for constant volume outside air flow. Outside air flow monitoring station required.

**CO2 =**

**Enable/None:** This will control the economizer for maximum CO<sub>2</sub> level. CO<sub>2</sub> sensor is required.

## Heat Pump Configuration

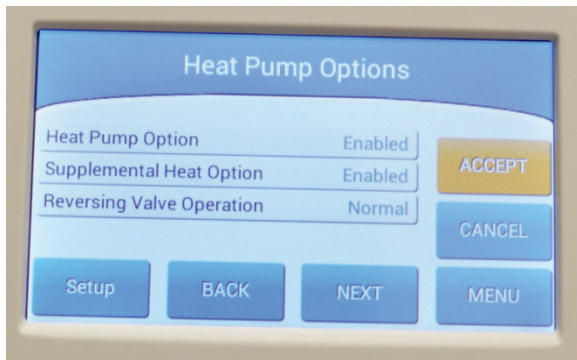

*Menu → Setup → Heat Pump Options*

**Heat Pump Option =**

**None/Enabled:** This will allow operation as a Heat Pump.

**Supplemental Heat Option =**

**None/Enabled:** This option allows supplemental auxiliary heat operation.

*This option does not apply when Heat Pump = None.*

**Reversing Valve Operation =**

**Normal:** Reversing valve is active during cooling. Valve is fail to heating.

**Inverted:** Reversing valve is active during heating. Valve is fail to cooling.

*This option does not apply when Heat Pump = None.*

## Dehumidification Configuration

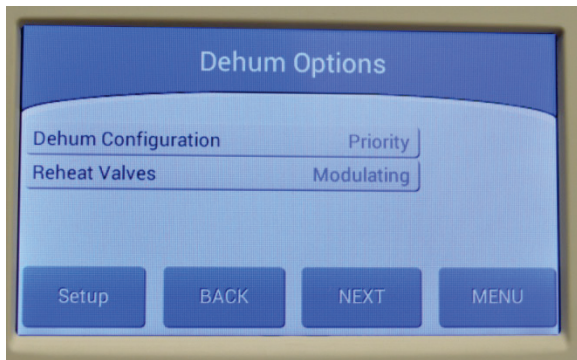

*Menu → Setup → Dehumidification Options*

### **Dehum Configuration =**

**None:** No Reheat/Dehumidification

**Priority:** This will operate Dehumidification Mode as a priority over Cooling, Heating, and Economizer Modes.

**Non-Priority:** This Reheat Configuration will operate Cooling, Heating, and Economizer Modes as a priority over Dehumidification Mode.

### **Reheat Valves =**

**Modulating:** Modulating Hot Gas Reheat Valve Operation

**On-Off:** On/Off Hot Gas Reheat Valve Operation

*This option does not apply when Dehum Configuration = None.*

## Exhaust Fan Configuration

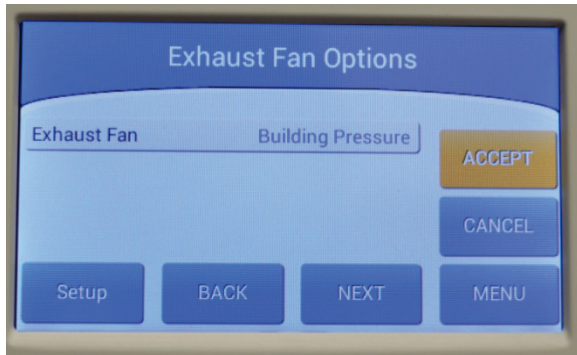

*Menu → Setup → Next → Exhaust Fan Options*

### **Exhaust Fan =**

**None:** No Exhaust Fan

**On/Off:** This operates the Exhaust Fan as an On/Off Fan. Exhaust fan operates when economizer opens above minimum position.

**Building Pressure:** This operates the Exhaust Fan to maintain building static pressure. Variable speed exhaust fan required.

## Network Configuration

Network Configuration

Protocol	BacNet	ACCEPT
Baud Rate	19200	
Bits/Parity/Stop	8/None/1	
Address	100	

Setup BACK NEXT MENU

CANCEL

Network Configuration

Protocol	Modbus	ACCEPT
Baud Rate	19200	
Bits/Parity/Stop	8/None/1	
Address	100	

Setup BACK NEXT MENU

CANCEL

*Menu → Setup → Next → Network Config*

**Protocol =**

**BACnet/Modbus:** This Protocol Option enables the BACnet or Modbus communications.

**Baud Rate:** This sets the bits per second on the RS-485 Com port 1.

**Bits/Parity/Stop:** This sets the configuration on the RS-485 Com port 1.

**Address:** This sets the unit network address.

## Security Configuration



**Menu** → **Setup** → **Next** → **Security**

**User Password: (0000)** User has access to I/O Alarms

**Manager Password: (1988)** Manager has access to Setpoints, I/O Alarms, and Schedule

**Administrator Password (2425)** - Admin has access to all menu screens - Setpoints, I/O Alarms, Schedule, and Setup

*Note: Administrator Password is required to set security passwords. If changed, keep a record of the new administrator password in a trusted location.*

## System Information

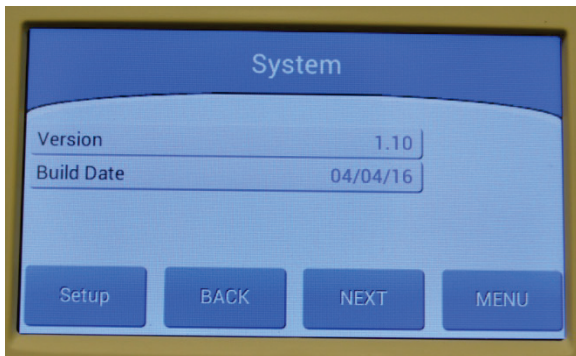

**Menu** → **Setup** → **Next** → **System**

**Version:** This is the running version of the firmware.

**Build Date:** This is the date when the firmware was released.



## Supply Fan Configuration

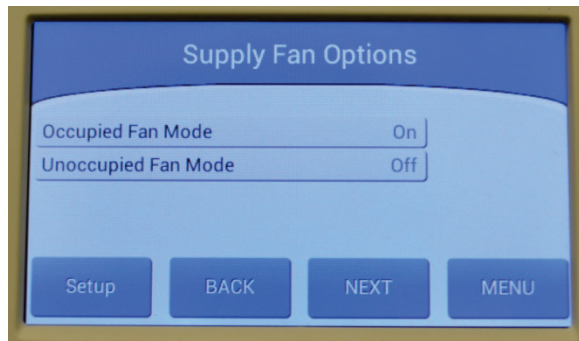

*Menu → Setup → Next → Supply Fan Options*

**Occupied Fan Mode =**

**On:** Supply fan is always on.

**Off:** Supply fan is always off.

**Auto:** Supply fan operates with heating, cooling, dehumidification modes.

**Unoccupied Fan Mode =**

**On:** Supply fan is always on.

**Off:** Supply fan is always off.

**Auto:** Supply fan operates with heating, cooling, dehumidification modes.

## Manual System Tests

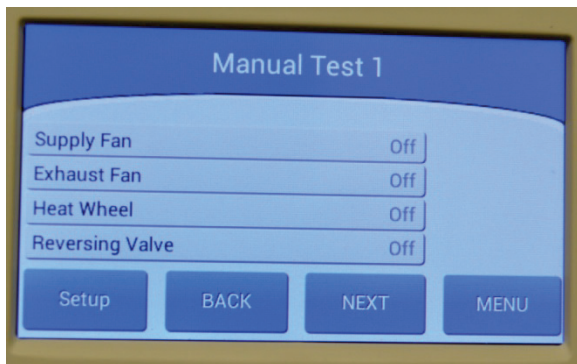
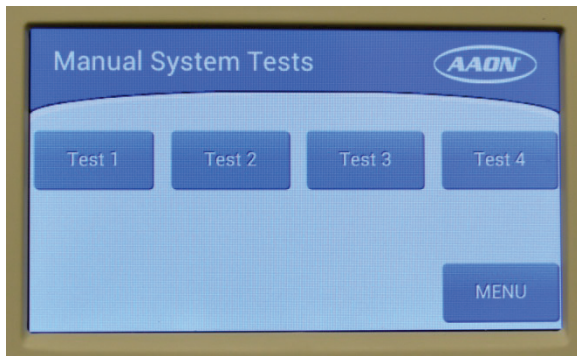

*Menu → Setup → Next → Manual Test*

**Test 1 =**

**Supply Fan:** Force fan to 100%. Supply fan must be active for heating and cooling to operate.

**Exhaust Fan:** Force fan to 100%

**Heat Wheel:** Energize wheel

**Reversing Valve:** Energize reversing valve

**Test 2 =**

**Economizer:** Force economizer open to 100%

**Reheat:** Force reheat to 100%

**Hot Water Valve:** Force open to 100%

**Chilled Water Valve:** Force open to 100%

**Test 3 =**

**Condenser Fan 1:** Force condenser fan to 100%

**Compressor 1:** Energize compressor or 95% capacity with variable capacity compressor. Supply fan must be active for compressor to operate.

**Condenser Fan 2:** Force condenser fan to 100%

**Compressor 2:** Energize compressor or 95% capacity with variable capacity compressor. Supply fan must be active for compressor to operate.

**Test 4 =**

**Heat Stage 1:** Energize heat stage 1.

**Heat Stage 2:** Energize heat stage 2.

**Heat Stage 3:** Energize heat stage 3.

**Heat Stage 4:** Energize heat stage 4.

*Supply fan must be active for heating and cooling to operate.*

*Manual override will automatically disable after 5 minutes on*

## Setpoint Adjustment

### Cooling Setpoints

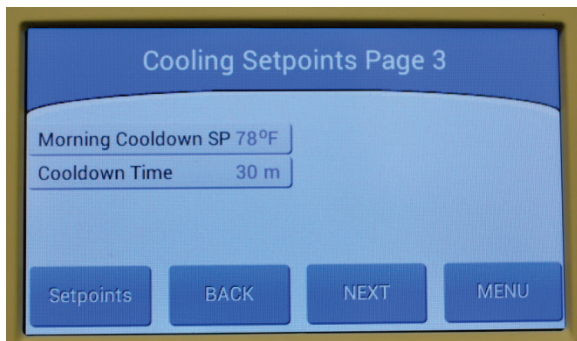
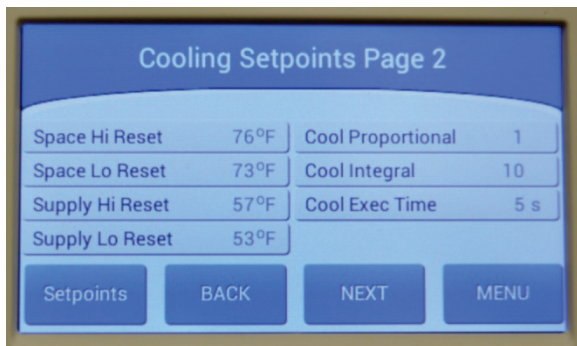
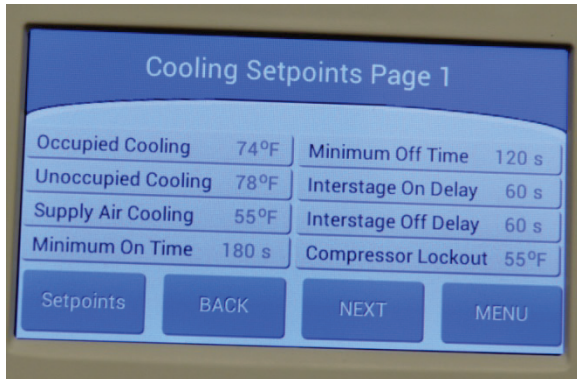

*Menu → Setpoints → Cool*

#### **Cooling Setpoints 1: Default Values**

Occupied Cooling = 74°F

(55-85°F Range)

Unoccupied Cooling = 78°F

(55-85°F Range)

Supply Air Temperature Cooling = 55°F

(45-65°F Range)

Compressor Minimum On Time = 180 sec

(120-255 sec Range)

Compressor Minimum Off Time = 120 sec

(60-255 sec Range)

Compressor Interstage On Delay = 60 sec

(30-255 sec Range)

Compressor Interstage Off Delay = 60 sec

(30-255 sec Range)

Outside Compressor Lockout Setpoint = 55°F

(-20-65°F Range)

*Cooling operation below 35°F requires a low ambient option.*

#### **Cooling Setpoints 2: Default Values**

Space Temperature High Reset = 76°F

(55-85°F Range)

Space Temperature Low Reset = 73°F

(55-85°F Range)

Supply Air Temperature High Reset = 57°F

(45-65°F Range)

Supply Air Temperature Low Reset = 53°F

(45-65°F Range)

Cooling Proportional = 1

Cooling Integral = 10

Cooling Execution Time = 5 sec

#### **Cooling Setpoints 3: Default Values**

Morning Cool-Down = 78°F

(55-85°F Range)

Morning Cool-Down Time = 30 min

(5-60 min Range)

## Heating Setpoints

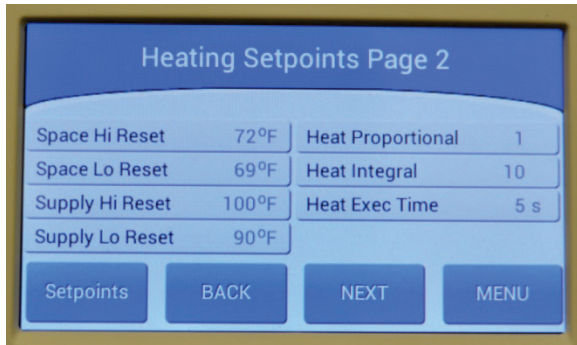
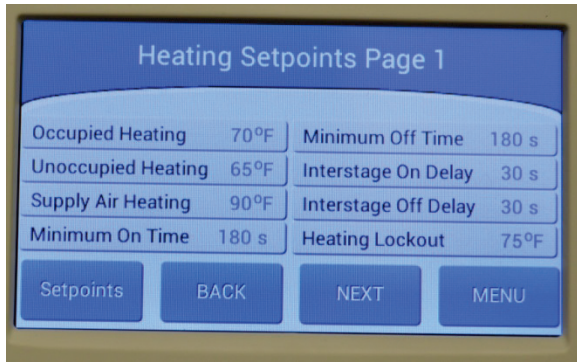

*Menu* → *Setpoints* → *Heat*

### Heating Setpoints 1: Default Values

Occupied Heating = 70°F  
(55-85°F Range)  
 Unoccupied Heating = 65°F  
(55-85°F Range)  
 Supply Air Temperature Heating = 90°F  
(55-120°F Range)  
 Heating Minimum On Time = 180 sec  
(120-255 sec Range)  
 Heating Minimum Off Time = 180 sec  
(120-255 sec Range)  
 Heating Interstage On Delay = 30 sec  
(30-255 sec Range)  
 Heating Interstage Off Delay = 30 sec  
(30-255 sec Range)  
 Heating Outside Air Temp Lockout = 75°F  
(50-100°F Range)

### Heating Setpoints 2: Default Values

Heating Space Temp High Reset = 72°F  
(55-85°F Range)  
 Heating Space Temp Low Reset = 69°F  
(55-85°F Range)  
 Heating Supply Temp High Reset = 100°F  
(55-120°F Range)  
 Heating Supply Temp Low Reset = 90°F  
(55-120°F Range)  
 Heating Proportional = 1  
 Heating Integral = 10  
 Heating Execution Time = 5 sec

### Heating Setpoints 3: Default Values

Morning Warm-Up = 65°F  
(50-85°F Range)  
 Morning Warm-Up Time = 30 min  
(5-60 min Range)  
 Preheat Outside Air Temperature = 35°F  
(10-60°F Range)  
 Preheat Leaving Air Temperature = 50°F  
(35-80°F Range)

## Dehumidification Setpoints

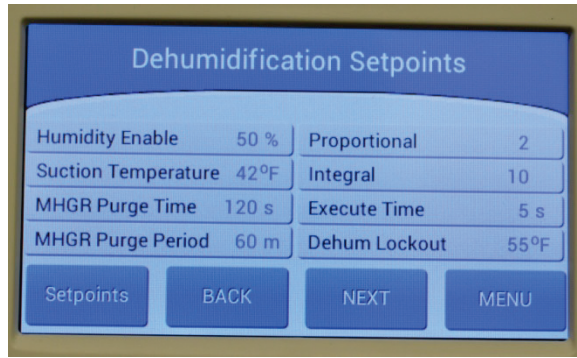

Dehumidification Setpoints			
Humidity Enable	50 %	Proportional	2
Suction Temperature	42°F	Integral	10
MHGR Purge Time	120 s	Execute Time	5 s
MHGR Purge Period	60 m	Dehum Lockout	55°F

Setpoints    BACK    NEXT    MENU

**Menu → Setpoints → Dehum**

### **Dehumidification Setpoints: Default Values**

Relative Humidity Enable = 50% RH  
(40-60% RH Range)

Evaporator Suction Temperature = 42°F  
(38-48°F Range)

MHGR Purge Time = 120 sec  
(60-240 sec Range)

MHGR Purge Period = 60 min  
(1-120 min Range)

Proportional = 2

Integral = 10

Execution Time = 5 sec

Dehumidification Lockout = 55°F  
(35-75°F Range)



## Economizer Setpoints

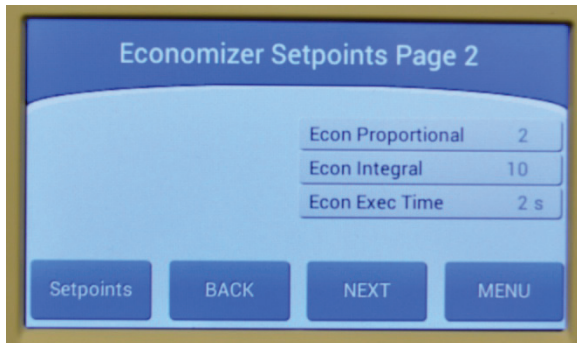
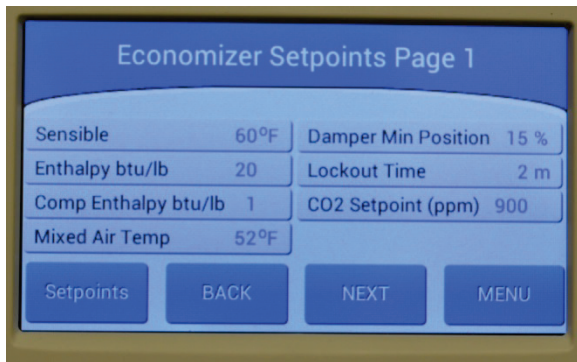

*Menu → Setpoints → Econ/CO2*

### **Economizer Setpoints Page 1: Default Values**

Sensible Economizer Enable = 60°F

(40-80°F Range)

Enthalpy Economizer Enable = 20 btu/lb

(15-25 btu/lb Range)

Comparative Enthalpy Economizer = 1 btu/lb

(1-5 btu/lb Range)

Mixed Air Temperature = 52°F

(50-80°F Range)

Economizer Damper Minimum Position = 15%

(0-100% Range)

Economizer Cooling Lockout Time = 2 min

(1-20 min Range)

CO<sub>2</sub> = 900 ppm

(500-1500 ppm Range)

### **Economizer Setpoints Page 2: Default Values**

Economizer Proportional = 2

Economizer Integral = 10

Economizer Execution Time = 2 sec



## Supply Fan Setpoints

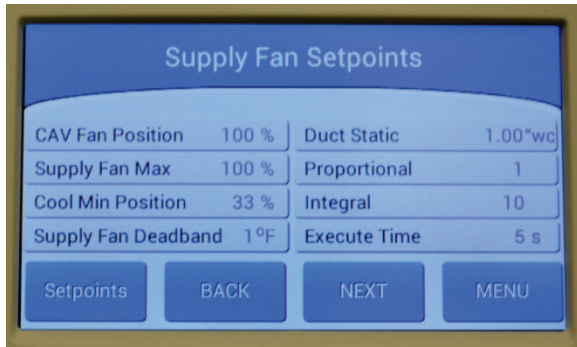

Supply Fan Setpoints			
CAV Fan Position	100 %	Duct Static	1.00*wc
Supply Fan Max	100 %	Proportional	1
Cool Min Position	33 %	Integral	10
Supply Fan Deadband	1°F	Execute Time	5 s
Setpoints	BACK	NEXT	MENU

*Menu → Setpoints → Supply Fan*

### **Supply Fan Setpoints: Default Values**

Constant Air Volume Position = 100%

(33-100% Range)

Supply Fan Max Position = 100%

(33-100% Range)

Cooling Minimum Position = 33%

(33-100% Range)

Supply Fan Deadband = 4°F

(2-10°F Range)

Duct Static = 1 in. w.c.

(0.25-2.50 in. w.c. Range)

Supply Fan Proportional = 1

Supply Fan Integral = 10

Supply Fan Execution Time = 5 sec

## Exhaust Fan Setpoints

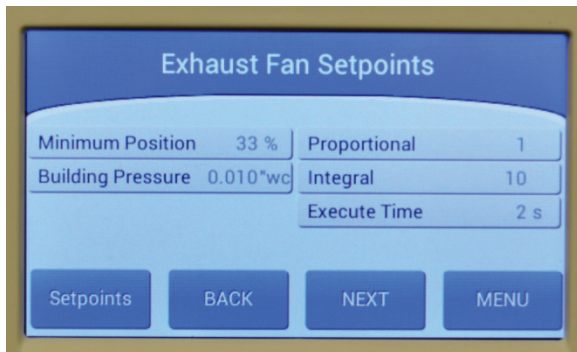

Exhaust Fan Setpoints			
Minimum Position	33 %	Proportional	1
Building Pressure	0.010*wc	Integral	10
		Execute Time	2 s
Setpoints	BACK	NEXT	MENU

*Menu → Setpoints → Exhaust Fan*

### **Exhaust Fan Setpoints: Default Values**

Exhaust Fan Minimum Position = 33%

(0-100% Range)

Building Static Pressure = 0.01 in. w.c.

(-0.1-0.1 in. w.c. Range)

Exhaust Fan Proportional = 1

Exhaust Fan Integral = 10

Exhaust Fan Execution Time = 2 sec

## Condenser Setpoints

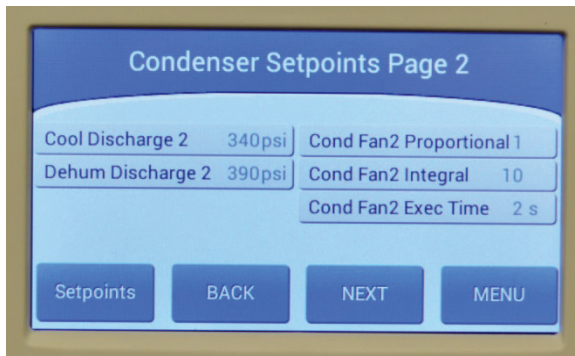
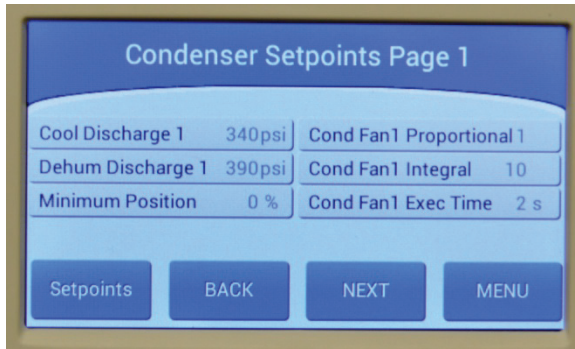

*Menu → Setpoints → Condenser*

### Condenser Setpoints 1: Default Values

Cooling Head Pressure/Discharge Pressure 1 = 340 psig (250-475 psig Range)

Dehumidification Head Pressure/Discharge Pressure 1 = 390 psig (250-475 psig Range)

Condenser Water Valve Minimum Position = 0% (0-100% Range)

Condenser Fan 1 Proportional = 1

Condenser Fan 1 Integral = 10

Condenser Fan 1 Execution Time = 2 sec

### Condenser Setpoints 2: Default Values

Cooling Head Pressure/Discharge Pressure 2 = 340 psig (250-475 psig Range)

Dehumidification Head Pressure/Discharge Pressure 2 = 390 psig (250-475 psig Range)

Condenser Fan 2 Proportional = 1

Condenser Fan 2 Integral = 10

Condenser Fan 2 Execution Time = 2 sec

## Heat Pump Setpoints

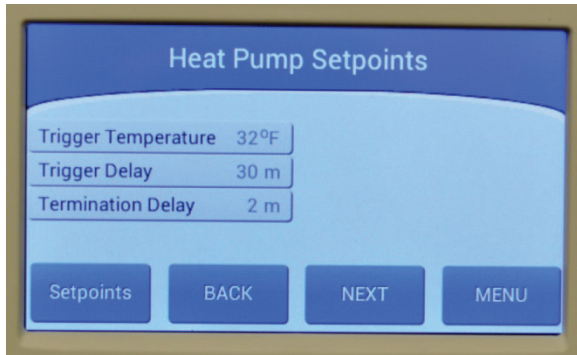

*Menu → Setpoints → Heat Pump*

### **Heat Pump Setpoints: Default Values**

Defrost Trigger Temperature = 32°F  
(0-40°F Range)

Defrost Trigger Delay = 30 min  
(1-60 min Range)

Defrost Termination Delay = 2 min  
(1-10 min Range)

## Outside Air Flow Monitoring Setpoints

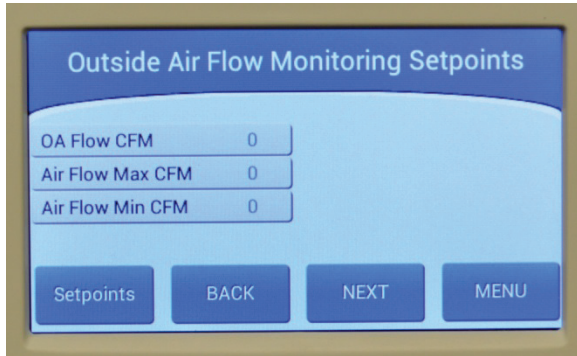

*Menu → Setpoints → Outside Air Flow*

### **Outside Air Flow Monitoring Setpoints: Default Values**

Outside Air Flow = 0 cfm  
(0-15000 cfm Range)  
Air Flow Scale Max = 0 cfm  
(0-15000 cfm Range)  
Air Flow Scale Min = 0 cfm  
(0-15000 cfm Range)

## Heat Wheel Setpoints



*Menu → Setpoints → Heat Wheel*

### **Heat Wheel Setpoints: Default Values**

Energy Recovery Wheel Minimum Run Time = 1 sec (1-60 sec)  
Energy Recovery Wheel Defrost = 25°F (0-35 Range)  
Energy Recovery Wheel Defrost Time = 120 sec (15-255 sec Range)  
Energy Recovery Wheel Defrost Period = 30 min (5-120 min Range)

## Sensor Calibration

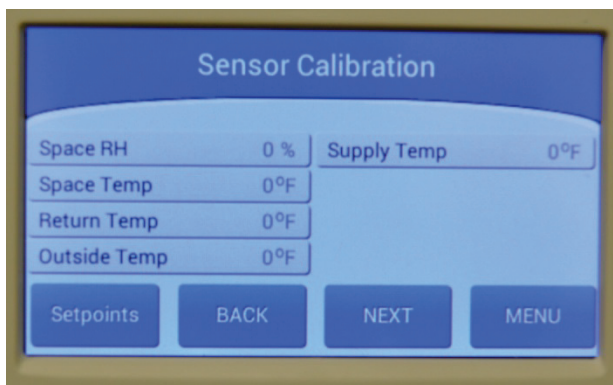

*Menu → Setpoints → Sensor Calibration*

### **Sensor Calibration**

Space Relative Humidity, Space Temperature, Return Air Temperature, Return Air Temperature, Outside Air Temperature, and Supply Air Temperature Sensor input values can be adjusted from this screen.

(-20°F to +20°F Range and -20%RH to 20%RH Range)

## Inputs, Outputs, and Alarms



**I/O - Alarms:** This allows access to Inputs, Outputs, General Alarms, and Shutdown Alarms.

## Inputs

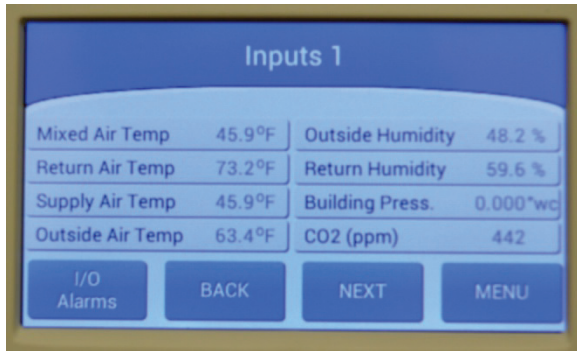

**Inputs:** Mixed Air Temperature, Return Air Temperature, Supply Air Temperature, Outside Air Temperature, Outside Air Humidity, Return Air Humidity Building Static Pressure, & CO<sub>2</sub>.

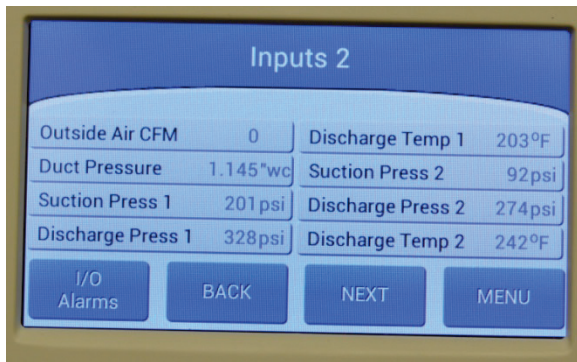

**Inputs:** Outside Air cfm, Duct Static Pressure, Suction Pressure 1, Discharge Pressure 1, Discharge Line Temperature 1, Suction Pressure 2, Discharge Pressure 2, & Discharge Line Temperature 2.



**Inputs:** Preheat Leaving Air Temperature A, Preheat Leaving Air Temperature B, Preheat Leaving Air Temperature Average, Remote Occupancy, Supply Fan Status, Emergency Shutdown, Water Flow, & Main Filter.



## Outputs



Outputs 1			
Supply Fan	Off	Reversing Valve	Off
Compressor 1	Off	Comp 1 Capacity	0 %
Compressor 2	Off	Comp 2 Capacity	0 %
Exhaust Fan	Off	Heat Wheel	Off
I/O Alarms    BACK    NEXT    MENU			

**Outputs:** Supply Fan, Compressor 1, Compressor 2, Exhaust Fan, Reversing Valve, Compressor 1 Capacity, Compressor 2 Capacity, & Heat Wheel.



Outputs 2			
Heat Stage 1	Off	Condenser Fan 1	0 %
Heat Stage 2	Off	Condenser Fan 2	0 %
Heat Stage 3	Off	Chilled Water	0 %
Heat Stage 4	Off	Hot Water Valve	0 %
I/O Alarms    BACK    NEXT    MENU			

**Outputs:** Heat Stage 1, Heat Stage 2, Heat Stage 3, Heat Stage 4, Condenser Fan 1, Condenser Fan 2, Chilled Water, & Hot Water Valve.

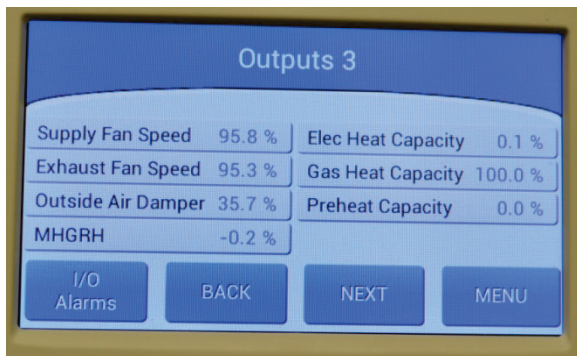

Outputs 3			
Supply Fan Speed	95.8 %	Elec Heat Capacity	0.1 %
Exhaust Fan Speed	95.3 %	Gas Heat Capacity	100.0 %
Outside Air Damper	35.7 %	Preheat Capacity	0.0 %
MHGRH	-0.2 %		
I/O Alarms    BACK    NEXT    MENU			

**Outputs:** Supply Fan Speed, Exhaust Fan Speed, Outside Air Damper, Modulating Hot Gas Reheat, Electric Heat Capacity, Gas Heat Capacity, & Preheat Capacity.



## General Alarms

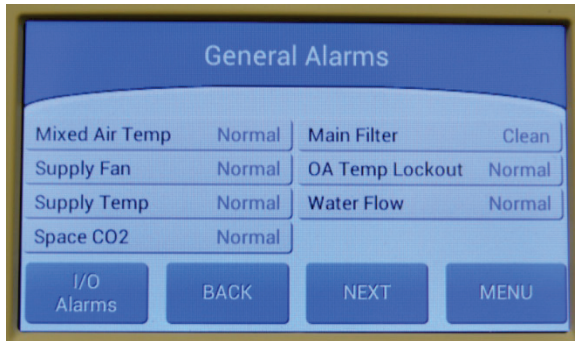

A Yellow Alarm Icon on the Home Screen, indicates a General Alarm.

### **General Alarms:**

**Mixed Air Temperature** - Activated if the mixed air temperature sensor has failed (Shorted or Open).

**Supply Fan** - Activated when there is no fan status signal within 60 seconds on a call for the supply fan (Airflow switch).

**Supply Air Temperature** - Low Limit Alarm is activated when the supply air temperature is below 25°F. Cooling will be disabled until supply air temperature is 2°F above 25°F. High Limit Alarm is activated when the supply air temperature is above the 200°F.

**Space CO<sub>2</sub>** - Activated when the CO<sub>2</sub> ppm is above the CO<sub>2</sub> setpoint. This alarm will open the economizer to increase ventilation to the space. Alarm is only available with CO<sub>2</sub> control configured.

**Main Filter** - Activated when the Clogged Filter Switch closes due to high differential pressure across the filter. The Alarm message will disable when the Clogged Filter Switch opens. This alarm is for informational purposes only, no change in equipment operation will occur.

**Outside Air Temperature Lockout** - Activated when the outside air temperature is below the compressor lockout temperature.

**Water Flow** - Activated when there is no water flow status signal within 60 seconds (Water Flow Switch).

## Shutdown Alarms

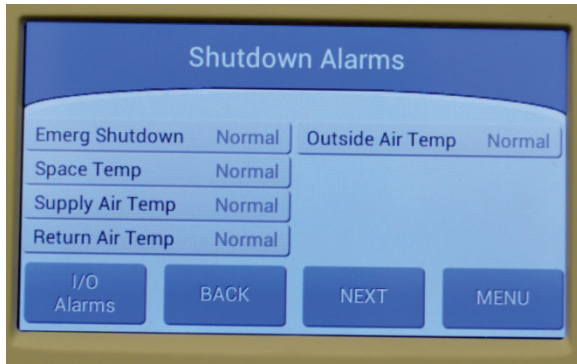

A Red Alarm Icon on the Home Screen indicates an Emergency Shutdown Alarm.

### **Shutdown Alarms:**

**Emergency Shutdown** - Activated when a safety circuit in the unit opens. Alarm will disable in the event that the safety circuit closes and a 30 second delay expires. Alarm will affect the unit's operation by forcing the unit into the Off Mode and disabling the Supply Fan.

**Space Temperature** - Activated if the space temperature sensor has failed (Shorted or Open). If this is the mode enable temperature sensor the Alarm will force the unit into Off mode and disable the Supply Fan.

**Supply Air Temperature** - Activated if the supply air temperature sensor has failed (Shorted or Open). This Alarm will affect the unit's operation by forcing the unit into Off Mode and disabling the Supply Fan.

**Return Air Temperature** - Activated if the return temperature sensor has failed (Shorted or Open). If this is the mode enable temperature sensor the Alarm will force the unit into Off Mode and disable the Supply Fan.

**Outside Air Temperature** - Activated if the outside air temperature sensor has failed (Shorted or Open). If this is the mode enable temperature sensor the Alarm will force the unit into Off Mode and disable the Supply Fan.

## Schedule Setup



**Schedule Screen:** The schedule screen allows schedule configuration for Monday, Tuesday, Wednesday, Thursday, Friday, Saturday, Sunday, Weekdays, Weekends, as well as, Time and Date adjustment.

One weekly schedule can be setup. Up to two occupied periods can be scheduled per day.

## Daily

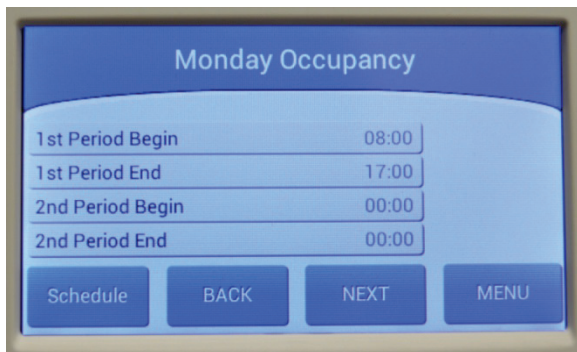

**Daily Occupancy:**

1<sup>st</sup> Period Begin is the start time for the first occupied period.

1<sup>st</sup> Period End is the end time for the first occupied period.

2<sup>nd</sup> Period Begin is the start time for the second occupancy period.

2<sup>nd</sup> Period End is the end time for the second occupancy period.

## Weekday and Weekend



**Weekday/Weekend Occupancy:**

1<sup>st</sup> Period Begin is the start time for the first occupancy period.

1<sup>st</sup> Period End is the end time for the first occupancy period.

2<sup>nd</sup> Period Begin is the start time for the second occupancy period.

2<sup>nd</sup> Period End is the end time for the second occupancy period.

Weekday/Weekend schedule has priority over all individual days.

## Date/Time



**Date and Time Screen:** This screen allows time and day of the week configuration.

**24 Hr Time (hh:mm):** Set the hour and minutes.

**Day of Week:** Set the day of week.

## Sequences of Operation

Note: All values listed are default values and some values are adjustable.

### Cooling Operation

Cooling Mode will only operate if the Supply Fan Status is Normal (Proof of Flow has been made).

Cooling Mode is enabled when the temperature of the Control Temp Sensor rises 1°F above the active Cooling Setpoint. Cooling Mode is disabled when the temperature at the Control Temp Sensor falls 1°F below the active Cooling Setpoint.

Compressor staging up and staging down are subject to the following setpoints:

Compressor Minimum On Time

Compressor Minimum Off Time

Compressor Interstage On Delay

Compressor Interstage Off Delay

Compressors are locked out if the outside air temperature falls 1°F below the Compressor Lockout Setpoint and will remain locked out until the Outside Air Temperature rises 1°F above the Compressor Lockout Setpoint. If the Outside Air Temperature falls below the Compressor Lockout Setpoint while the compressors are operating, mechanical cooling will stage off as minimum run times and stage down delays allow.

If the economizer is enabled, it will function as the first stage of cooling.

### **1 On/Off Compressor**

In Cooling Mode, the compressor will be enabled.

### **On/Off and Two-Step Scroll Compressors**

#### *Stage Up Sequence:*

In Cooling Mode, as the supply air temperature rises above the active Supply Air Temperature Cooling setpoint, cooling will begin to stage on.

#### *Stage Down Sequence:*

In Cooling Mode, as the supply air temperature falls below the active Supply Air Temperature Cooling setpoint, cooling will begin to stage off.

### **1 Variable Capacity Scroll Compressor**

#### *Stage Up Sequence:*

In Cooling Mode, as the supply air temperature rises above the active Supply Air Temperature Cooling setpoint, the variable capacity scroll compressor will stage on and begin to modulate to maintain the active Supply Air Temperature Cooling Setpoint.

#### *Stage Down Sequence:*

In Cooling Mode, as the supply air temperature falls below the active Supply Air Temperature Cooling setpoint, the variable capacity scroll compressor will modulate to maintain the active Supply Air Temperature Cooling setpoint. If the variable capacity compressor is at minimum

capacity, and the supply air temperature is still below the active Supply Air Temperature Cooling setpoint within the Cooling Interstage Delay, then the variable capacity compressor will stage off.

### **1 Variable Capacity Scroll Compressor and 1 On/Off Scroll Compressor**

#### *Stage Up Sequence:*

In the Cooling Mode, as the supply air temperature rises above the active Supply Air Temperature Cooling setpoint, the variable capacity scroll compressor will stage on and begin to modulate to maintain the active Supply Air Temperature Cooling Setpoint. If the variable capacity compressor is at 100% and the active Supply Air Temperature Cooling Setpoint is not satisfied within the Cooling Interstage Delay, the additional on/off compressor will stage on and the variable capacity compressor will reset back to minimum capacity, then modulate to maintain the active Supply Air Temperature Cooling setpoint.

#### *Stage Down Sequence:*

In the Cooling Mode, as the supply air temperature falls below the active Supply Air Temperature Cooling setpoint, with the variable capacity compressor at 100% and the on/off compressor Enabled, the variable capacity scroll compressor will modulate to maintain the active Supply Air Temperature Cooling setpoint. If the variable capacity compressor is at minimum, and the supply air temperature is still below the active Supply Air Temperature Cooling setpoint within the Cooling Interstage Delay, the on/off compressor will stage off and the variable capacity compressor will reset back to 100%, then modulate as needed to maintain the active Supply Air Temperature Cooling setpoint. If the supply air temperature is still below the active Supply Air Temperature Cooling setpoint, and the variable capacity compressor is at minimum, then the variable capacity compressor will stage off.

### **All Variable Capacity Scroll Compressors**

#### *Stage Up Sequence:*

In Cooling Mode, as the supply air temperature rises above the active Supply Air Temperature Cooling setpoint, the first variable capacity scroll compressor will stage on and begin to modulate to maintain the Supply Air Temperature Cooling setpoint. If the first variable capacity scroll compressor is at 100% and the active Supply Air Temperature Cooling setpoint is not satisfied within the Cooling Interstage Delay, the second variable capacity scroll compressor will stage on and both variable capacity compressors will modulate to maintain the active Supply Air Temperature Cooling setpoint.

#### *Stage Down Sequence:*

In Cooling Mode, as the supply air temperature falls below the active Supply Air Temperature setpoint, the variable capacity control compressors will modulate to maintain the active Supply Air Temperature Cooling setpoint. Once the demand falls below the need for the second compressor within the time of the Cooling Interstage Delay and the compressor's minimum on time has been satisfied, the second variable capacity scroll compressor will stage off, and the first variable capacity scroll compressor will continue to modulate as needed to maintain the Supply Air Temperature Cooling setpoint. Additionally, if the supply air temperature falls below the active Supply Air Temperature Cooling setpoint, the first variable capacity scroll compressor will stage off.

### **Modulating Chilled Water Coil**

In Cooling Mode, as the supply air temperature rises above the Supply Air Temperature Cooling setpoint, the chilled water valve will begin to modulate to maintain the Supply Air Temperature Cooling setpoint.

### Space-Supply Cooling Reset

Space-Supply Cooling Reset reads the Space Temperature and linearly calculates a Supply Air Temperature setpoint.

Space-Supply Cooling Reset is subject to the following setpoints:

Space Temp Cool Hi

Space Temp Cool Lo

Supply Temp Cool Hi

Supply Temp Cool Lo

The Supply Air reset calculation will hold the Supply Temp Hi setpoint if the space temperature is below the Space Temperature Lo setpoint. As the Space Temperature increases above the Space Temp Lo setpoint and toward the Space Temp Hi setpoint, the supply air setpoint calculation will decrease in a linear fashion toward the Supply Temp Lo setpoint. The Supply Air reset calculation will hold the Supply Temp Lo setpoint if the space temperature is above the Space Temp Hi setpoint.

In the example below, the Supply Air Temp setpoint decreases linearly from 60°F to 50°F as the space temperature increases from 72°F to 76°F. When the space temperature is outside of those ranges, the Supply Air Temp setpoint will remain at the Hi or Lo values; at 70°F space temperature the Supply Air Temp setpoint will remain at the Supply Temp Cool Hi setpoint, 60°F, and at 78°F space temperature the Supply Air Temp setpoint will remain at the Supply Temp Cool Lo setpoint, 50°F.

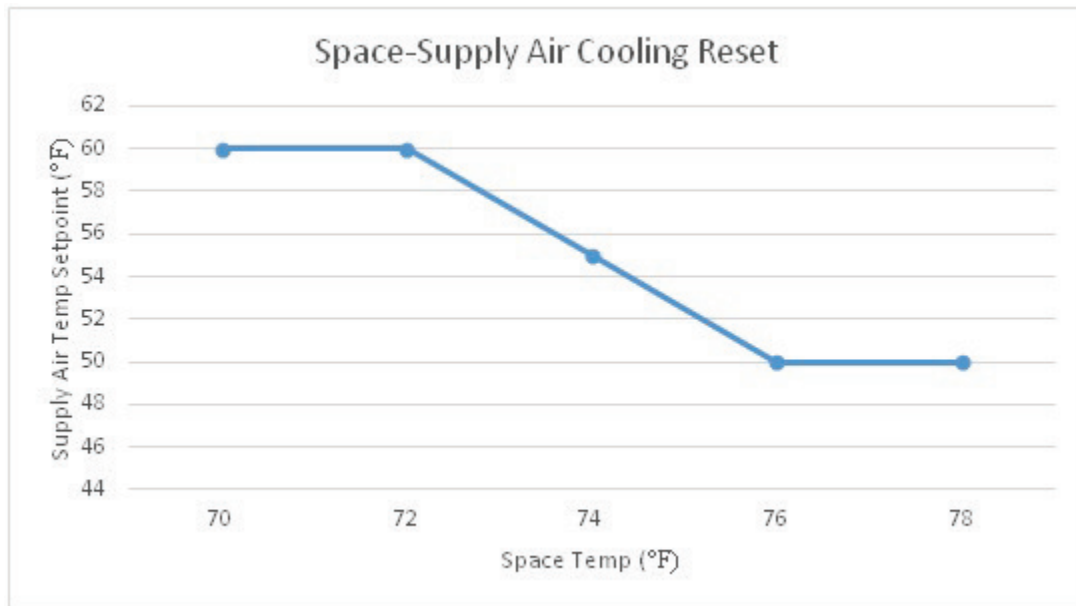

Figure 21 - Space-Supply Air Cooling Reset Example

### Morning Cool-Down (VAV Only)



To enter Morning Cool-Down, the controller must transition from Unoccupied to Occupied Mode, the Supply Fan Status must be closed with the 30 sec air flow timer expired, and the return air temperature must be above the Morning Cool-Down setpoint.

During Morning Cool-Down, the outside air damper will remain closed, and the controller will enter cooling mode and maintain the Supply Cooling setpoint for the duration of the Cool-Down time, or until the return air temperature falls below the Morning Cool-Down setpoint.

### Heating Operation

Heating Mode will only operate if the Supply Fan Status is Normal ( Proof of Flow has been made).

Heating Mode is enabled when the temperature of the Control Temp Sensor falls 1°F below the active Heating setpoint. Heating Mode is disabled when the temperature at the Control Temp Sensor rises 1°F above the active Heating setpoint.

Heat staging up and staging down are subject to the following setpoints:

- Heating Minimum On Time
- Heating Minimum Off Time
- Heating Interstage On Delay
- Heating Interstage Off Delay

### **Staged Heating**

In Heating Mode, as the supply air temperature falls below the active Supply Air Temperature Heating setpoint, the heating will begin to stage on. As the supply air temperature rises above the active Supply Air Temperature Heating setpoint, heating will begin to stage off.

Note: If the unit is set up for only one on/off stage of heating, the heating stage will be enabled in Heating Mode.

### **Modulating Gas Heat**

In Heating Mode, the modulating gas heat control board will operate the heat exchangers to maintain the Supply Air Temperature Heating setpoint. The Supply Air Temperature Heating setpoint will be adjustable within the unit controller and communicated to the modulating gas control board.

### **Modulating Electric Heat**

#### *Stage Up Sequence:*

In Heating Mode, as the supply air temperature falls below the Supply Air Temperature Heating setpoint, the modulating stage of heat will begin to modulate to maintain the Supply Air Temperature Heating setpoint. If the modulating stage of heat reaches 100% for the duration of the Heat Interstage Delay setpoint, the available subsequent heat stages will be staged on, and the modulating heat stage will continue to modulate with each heat stage to maintain the Supply Air Temperature Heating setpoint.

#### *Stage Down Sequence:*

As the supply air temperature rises above the Supply Air Temperature Heating setpoint, the modulating stage of heat will modulate to maintain the Supply Air Temperature Heating setpoint. If the modulating stage of heat reaches 0% for the duration of the Heat Interstage Delay setpoint, the currently active heating stages will begin to be staged off, and the modulating heat stage will continue to modulate with each stage to maintain the Supply Air Temperature Heating setpoint.

### **Modulating Hot Water**

In Heating Mode, as the supply air temperature falls below the Supply Air Temperature Heating setpoint, the hot water valve will begin to modulate to maintain the Supply Air Temperature Heating setpoint.

### **Space–Supply Heating Reset**

Space-Supply Heating Reset reads the Space Temperature and linearly calculates a Supply Temperature setpoint.

Space-Supply Heating Reset is subject to the following setpoints:

Space Temp Heat Hi

Space Temp Heat Lo

Supply Temp Heat Hi

Supply Temp Heat Lo

The Supply Air reset calculation will hold the Supply Temp Hi setpoint if the space temperature is below the Space Temperature Lo setpoint. As the Space Temperature increases above the Space Temp Lo setpoint and toward the Space Temp Hi setpoint, the Supply Air setpoint calculation will decrease in a linear fashion toward the Supply Temp Lo setpoint. The Supply Air reset calculation will hold the Supply Temp Lo if the space temperature is above the Space Temp Hi setpoint.

In the example below, the Supply Air Temp setpoint decreases linearly from 95°F to 85°F as the space temperature increases from 68°F to 72°F. When the space temperature is outside of those ranges, the Supply Air Temp setpoint will remain at the Hi or Lo values; at 66°F space temperature

the Supply Air Temp setpoint will remain at the Supply Temp Cool Hi setpoint, 95°F, and at 74°F space temperature the Supply Air Temp setpoint will remain at the Supply Temp Cool Lo setpoint, 85°F.

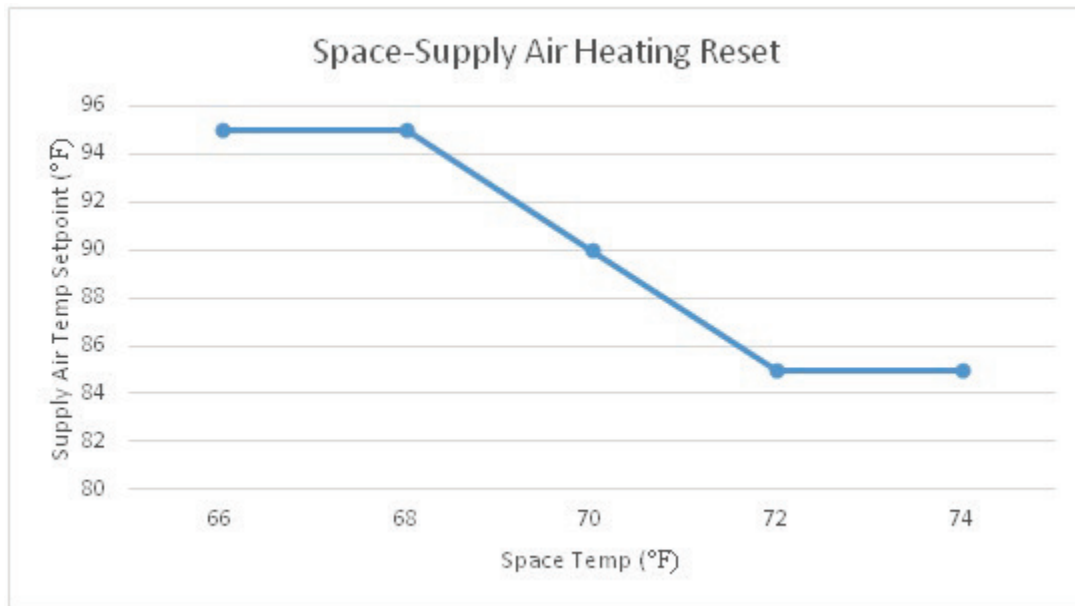

Figure 22 - Space-Supply Air Heating Reset Example

### **Daytime Heat (VAV Only)**

Daytime Heat can only be initialized via the BACnet protocol (VAV Daytime Heat).

Once the BACnet point is set to true, the unit will index Heating Mode. Heating Mode will operate to maintain the active Heating Supply Air Temperature setpoint.

### **Morning Warm-Up (VAV Only)**

To enter Morning Warm-Up, the controller must transition from Unoccupied to Occupied Mode, the Supply Fan Status must be closed with the 30 sec air flow timer expired, and the return air temperature must be below the Morning Warm-Up setpoint.

During Morning Warm-Up, the outside air damper will remain closed, and the controller will enter Heating Mode and maintain the Supply Heating setpoint for the duration of the Warm-Up time, or until the return air temperature rises above the Morning Warm-Up setpoint.

### **Dehumidification Operation**

Dehumidification Mode will only operate if the Supply Fan Status is Normal (Proof of Flow has been made).

Dehumidification Mode is enabled based on the Dehumidification Enable setpoint. The Control Humidity Sensor configuration will be the controlling sensor for Dehumidification Mode.

Dehumidification can be selected as a priority mode and will be active anytime the humidity is above the Dehumidification Enable setpoint. Otherwise, it is only available when the Cooling and Heating demands are satisfied.

Compressor staging up and staging down are subject to the following setpoints:

Compressor Minimum On Time

Compressor Minimum Off Time

Compressor Interstage On Delay

Compressor Interstage Off Delay

Compressors are locked out if the outside air temperature falls 1°F below the Compressor Lockout Setpoint and will remain locked out until the Outside Air Temperature rises 1°F above the Compressor Lockout Setpoint. If the Outside Air Temperature falls below the Compressor Lockout Setpoint while the compressors are operating, mechanical cooling will stage off as minimum run times and stage down delays allow.

### **On/Off and Two-Step Scroll Compressors**

#### *Stage Up Sequence:*

In Dehumidification Mode, as the first stage suction pressure rises above the Evaporator Coil Suction Temperature setpoint, the compressors will begin to stage on.

#### *Stage Down Sequence:*

In Dehumidification Mode, as the first stage suction pressure falls below the Evaporator Coil Suction Temperature setpoint, the compressors will begin to stage off.

### **1 Variable Capacity Scroll Compressor**

#### *Stage Up Sequence:*

In Dehumidification Mode, as the first stage suction pressure rises above the Evaporator Coil Suction Temperature setpoint, the variable capacity scroll compressor will stage on and begin to modulate to maintain the Evaporator Coil Suction Temperature setpoint.

#### *Stage Down Sequence:*

In Dehumidification Mode, as the first stage suction pressure falls below Evaporator Coil Suction Temperature setpoint, the variable capacity scroll compressor will modulate to maintain the Evaporator Coil Suction Temperature setpoint. If the variable capacity compressor is at minimum, and the supply air temperature is still below the Evaporator Coil Suction Temperature setpoint within the Cooling Interstage Delay, then the variable capacity compressor will stage off.

### **1 Variable Capacity Scroll Compressor and 1 On/Off Scroll Compressor**

#### *Stage Up Sequence:*

In Dehumidification Mode, as the first stage suction pressure rises above the Evaporator Coil Suction Temperature setpoint, the variable capacity scroll compressor will stage on and begin to modulate to maintain the active Evaporator Coil Suction Temperature setpoint. If the variable capacity compressor is at 100% and the Evaporator Coil Suction Temperature setpoint is not satisfied within the Cooling Interstage Delay, the additional on/off compressor will stage on and the variable capacity compressor will then modulate to maintain the Evaporator Coil Suction Temperature setpoint.

#### *Stage Down Sequence:*

In Dehumidification Mode, as the first stage suction pressure falls below the Evaporator Coil Suction Temperature setpoint, with the variable capacity compressor at 100% and the on/off compressor Enabled, the variable capacity scroll compressor will modulate to maintain the

Evaporator Coil Suction Temperature setpoint. If the variable capacity compressor is at minimum, and the supply air temperature is still below the Evaporator Coil Suction Temperature setpoint within the Cooling Interstage Delay, the on/off compressor will stage off and the variable capacity compressor will reset back to 100%, then modulate as needed to maintain the Evaporator Coil Suction Temperature setpoint. If the supply air temperature is still below the Evaporator Coil Suction Temperature setpoint, and the variable capacity compressor is at minimum, then the variable capacity compressor will stage off.

### **All Variable Capacity Scroll Compressors**

#### *Stage Up Sequence:*

In Dehumidification Mode, as the first stage suction pressure rises above the Evaporator Coil Suction Temperature setpoint, the first variable capacity scroll compressor will stage on and begin to modulate to maintain the Evaporator Coil Suction Temperature setpoint. If the first variable capacity scroll compressor is at 100% and the Evaporator Coil Suction Temperature setpoint is not satisfied within the time of the Cooling Interstage Delay, the second variable capacity scroll compressor will stage on and both variable capacity compressors will modulate to maintain the Evaporator Coil Suction Temperature setpoint.

#### *Stage Down Sequence:*

In Dehumidification Mode, as the first stage suction pressure falls below the Evaporator Coil Suction Temperature setpoint, the variable capacity control compressors will modulate to maintain the Evaporator Coil Suction Temperature setpoint. Once the demand falls below the need for the second compressor within the time of the Cooling Interstage Delay and the compressor's minimum on time has been satisfied, the second variable capacity scroll compressor will stage off, and the first variable capacity scroll compressor will continue to modulate as needed to maintain the Evaporator Coil Suction Temperature setpoint. Additionally, if the supply air temperature falls below the Evaporator Coil Suction Temperature setpoint, the first variable capacity scroll compressor will stage off.

### **Hot Gas Reheat**

Hot Gas Reheat will operate only during Dehumidification Mode.

#### *Stage Up Sequence:*

As the Mode Enable temperature rises 1°F above the Occupied Cooling setpoint, the Hot Gas Reheat Solenoid will stage on.

#### *Stage Down Sequence:*

As the Mode Enable temperature falls 1°F below the Occupied Cooling setpoint, the Hot Gas Reheat Solenoid will stage off.

### **Modulating Hot Gas Reheat**

Modulating Hot Gas Reheat (MHGR) will operate only during Dehumidification Mode.

As the Mode Enable temperature rises above the Occupied Cooling setpoint, the MHGR will modulate to maintain the Occupied Cooling setpoint.

### **Reheat Purge Mode**

After dehumidification has been operating for one hour, the purge cycle will fully open the reheat valves for two minutes every sixty minutes if the reheat valve position is less than thirty percent.

This cycle will continue to operate for the entirety of Dehumidification Mode, and at the start-up of each compressor.

## Occupancy/Supply Fan Operation

### **Building Occupancy Status**

Occupied Mode Operation Options:

Internal Schedule

Remote Forced Occupied (Normally Open Contact, DI1)

Network Occupancy Point (BACnet)

### *Occupied Mode Operation*

The controller will use occupied setpoints for heating cooling and dehumidification modes of operation.

### *Unoccupied Mod Operation*

If the Unoccupied Mode setpoint is set to ON, the controller will use unoccupied setpoints for heating and cooling mode operations, the controller will use the occupied dehumidification mode setpoint for dehumidification mode, the outside air damper will be closed, and calls for heating, cooling, or dehumidification will operate based on the unoccupied Supply Fan mode selection. If the Unoccupied Mode setpoint is set to OFF, the unit will be off.

### **Supply Fan**

Anytime the supply fan is request to start, a 30 sec minimum off timer must be satisfied. If the timer is satisfied the Supply Fan will be energized. In Auto mode or when transitioning to Unoccupied Mode the supply fan is held on for 1 minute after the last stage of cooling, heating, or dehumidification stages off.

### *Occupied Mode*

The Supply Fan can be configured for three modes:

(On) – To run continuously,

(Auto) – Cycles on with cooling, heating, and dehumidification modes, or

(Off) – Unit will not run with cooling, heating, and dehumidification demands.

### *Unoccupied Mode*

The Supply Fan can be configured for three modes:

(On) – To run continuously,

(Auto) – Cycles on with cooling, heating, and dehumidification modes, or

(Off) – Unit will not run with cooling, heating, and dehumidification demands.

### **Ventilation Mode**

This mode occurs during the Occupied or Unoccupied Mode of operation when there is no demand for cooling, heating, or dehumidification. The Supply Fan must be configured for continuous (ON) operation.

### **Single Zone VAV**



### *Cooling*

In Cooling Mode, as the control temperature sensor rises above the Occupied Cooling setpoint, the supply fan shall modulate up linearly based on the supply fan deadband. As the control temperature sensor falls toward the Occupied Cooling Setpoint, the supply fan shall modulate down.

### *Heating*

The supply fan shall run at a constant speed.

### *Dehumidification*

The supply fan shall run at a constant speed.

### **Constant Volume and Makeup Air**

#### *Cooling, Heating, and Dehumidification*

The supply fan shall run at a constant speed.

### **Variable Air Volume**

During Occupied Mode, the supply fan will modulate to maintain Duct Static Pressure Setpoint.

## Additional Feature Sequences

### **Economizer Operation**

Note: For Title 24 compliance, unit must be selected with Fault Detection and Diagnostics Controller

**Sensible Economizer** operation is enabled when the outside air temperature falls below the Sensible Economizer Enable setpoint by 1°F. Economizer operation is disabled when the outside air temperature rises 1°F above the Sensible Economizer Enable setpoint.

**Enthalpy Economizer** is enabled when the outside air enthalpy falls below the Enthalpy Economizer Enable setpoint by 1 Btu/lb and the outside air temperature falls below the Sensible Economizer Enable setpoint by 1°F. Economizer operation is disabled when the outside air enthalpy rises 1 Btu/lb above the Enthalpy Economizer Enable setpoint or the outside air temperature rises 1°F above the Sensible Economizer Enable setpoint.

**Comparative Enthalpy Economizer** is enabled when the difference between the return air enthalpy and outside air enthalpy rises 1 Btu/lb above the Comparative Enthalpy Economizer Enable setpoint, and the outside air temperature falls below the Sensible Economizer Enable setpoint by 1°F. Economizer operation is disabled when the difference between the return air enthalpy and the outside air enthalpy falls 1 Btu/lb below the Comparative Enthalpy Economizer Enable setpoint or the outside air temperature rises 1°F above the Sensible Economizer Enable setpoint. (Comparative Enthalpy = Outside Air Enthalpy – Return Air Enthalpy)

Economizer acts as the first stage of cooling and modulates the outside air damper to maintain the Supply Air Temperature setpoint. If the Economizer reaches 100%, the Economizer Cooling Lockout Time has expired, and the supply air temperature is higher than 1°F of the Supply Air Cooling setpoint, mechanical cooling is allowed to stage up.

Economizer Damper Minimum Position setpoint can be adjusted in the controller.

The Economizer Damper is closed during Unoccupied Mode.

### **CO<sub>2</sub> Control Operation**

During Occupied Mode, as the CO<sub>2</sub> (Space or Return sensor) rises above the CO<sub>2</sub> setpoint, the outside air damper will modulate open. The outside air damper will take the maximum of the CO<sub>2</sub>, Economizer, or Outside Air Flow Monitoring Control signals.

### **Outside Air Flow Monitoring**

The scale of the Air Flow Monitoring Station must be configured to ensure accurate control. The Minimum and Maximum Scale settings will be coordinated with a 0-10VDC input.

During Occupied Mode, as the Outside Air Flow falls below the Outside Air Flow setpoint, the outside air damper will modulate open within a range of the Outside Air Minimum Position to 100%. As the Outside Air Flow rises above the Outside Air Flow setpoint, the outside air damper will modulate closed with a range of 100% to the Outside Air Minimum Position.

### **Head Pressure Control**

#### **Combined Condenser Head Pressure Control**

The condenser fan is commanded on when the compressor is enabled.

In Cooling Mode, as the controlling discharge pressure rises above the Cool Discharge 1 setpoint, the condenser fan will modulate to maintain the Cool Discharge 1 setpoint. If there are two refrigerant circuits, the controlling discharge pressure is the highest of the two circuits.

In Dehumidification Mode, as the controlling discharge pressure rises above the Dehum Discharge 1 setpoint, the condenser fan will modulate to maintain the Dehum Discharge 1 setpoint. If there are two refrigerant circuits, the controlling discharge pressure is the highest of the two circuits.

#### **Split Condenser Head Pressure Control**

Each condenser fan is commanded on when its corresponding compressor is enabled.

In Cooling Mode, as the discharge pressure for circuit 1 rises above the Cool Discharge 1 setpoint, the condenser fan will modulate to maintain the Cool Discharge 1 setpoint.

In Cooling Mode, as the discharge pressure for circuit 2 rises above the Cool Discharge 2 setpoint, the condenser fan will modulate to maintain the Cool Discharge 2 setpoint.

In Dehumidification Mode, as the discharge pressure for circuit 1 rises above the Dehum Discharge 1 setpoint, the condenser fan will modulate to maintain the Dehum Discharge 1 setpoint.

In Dehumidification Mode, as the discharge pressure for circuit 2 rises above the Dehum Discharge 2 setpoint, the condenser fan will modulate to maintain the Dehum Discharge 2 setpoint.

Each condenser fan will operate independently and control to maintain its own Head Pressure setpoint.

#### **Water-Cooled Condenser with Head Pressure Control**

Condenser Water Flow Status must be confirmed before mechanical cooling will start (Water Flow Switch must be made).

The condenser valve modulates to the Condenser Water Valve Minimum Position setpoint when Cooling Mode is disabled.

In Cooling Mode, as the maximum of all discharge pressures rises above the Head Pressure setpoint, the condenser valve will modulate to maintain the Head Pressure setpoint.

### **Exhaust Fan Operation**

#### **Exhaust Fan without VFD or ECM**

The Exhaust Fan shall operate when the Supply Fan Proof of Flow is confirmed, and only during Occupied Mode when the outside air damper rises above the outside air damper minimum position.

#### **Exhaust Fan with VFD**

The Exhaust Fan shall operate when the Supply Fan Proof of Flow is confirmed, and only during Occupied Mode. As the Building Static Pressure rises above the Building Static Pressure setpoint, the Exhaust Fan will modulate to maintain the Building Static Pressure setpoint.

### **Heat Pump Operation**

During Heating Mode, the Outdoor Fan or Water Valve will be held at 100%

Heat Pump Auxiliary Heat is defined as supplemental heat to the compressor heating.

In Heating Mode, Auxiliary Heat is allowed to operate during the compressor operation. During

Defrost Mode, Auxiliary heat will be used in attempt to maintain the active Supply Air Heating setpoint.

Heat Pump Emergency Heat is defined as heat that is only allowed to operate when compressor heating is locked out.

### **Energy Recovery Wheel Operation**

The Energy Recovery Wheel shall operate when the Supply Fan Proof of flow is confirmed, and only during Occupied Mode. The Energy Recovery Wheel shall not operate during Economizer Mode.

### **Energy Recovery Wheel Defrost**

If the Energy Recovery Wheel has been on for a time greater than the Energy Recovery Wheel Minimum Run Time setpoint, and the outside air temperature is less than the Energy Recovery Wheel Defrost Setpoint, the defrost cycle will initiate.

The Energy Recovery Wheel will be turned off for the Energy Recovery Wheel Defrost Time; once expired, the Energy Recovery Wheel will be turned on again. The Energy Recovery Wheel Defrost Cycle will repeat after the Energy Recovery Wheel Defrost Period expires.

### **Modulating Electric Preheat**

The outside air temperature must be below the Preheat OAT setpoint, the unit must be in Occupied Mode, and the Supply Fan Status must be closed.

The preheat controller will modulate the electric preheat to maintain the Preheat Leaving Air Temperature setpoint.

## Network Points List

Table 3 - BACnet Points List (Analog Values 1)

Object	Description	Read/Write	Unit	Default	Min	Max
AV0	Discharge Press 1	R	psig			
AV1	Discharge Press 2	R	psig			
AV2	Suction Press 1	R	psig			
AV3	Suction Press 2	R	psig			
AV4	Discharge Temp 1	R	°F			
AV5	Discharge Temp 2	R	°F			
AV6	Mixed Air Temp	R	°F			
AV7	Return Air Temp	R	°F			
AV8	Supply Air Temp	R	°F			
AV9	Outside Air Temp	R	°F			
AV10	Return RH	R	% RH			
AV11	Outside RH	R	% RH			
AV12	CO2	R	ppm			
AV13	OA Airflow	R	cfm			
AV14	Duct Press	R	in. w.c.			
AV15	Building Press	R	in. w.c.			
AV16	Hot Water Valve	R	%			
AV17	Chilled Water Valve	R	%			
AV18	Condenser Fan 1	R	%			
AV19	Condenser Fan 2	R	%			
AV20	MHGRH	R	%			
AV21	Exhaust Fan	R	%			
AV22	Outside Air Damper	R	%			
AV23	Supply Fan	R	%			
AV24	Control Temp	R	°F			
AV25	Control RH	R	% RH			
AV26	Working Clg Spt	R	°F			
AV27	Working Htg Spt	R	°F			
AV28	Clg PID Count	R				
AV29	Digital Comp 1	R	%			
AV30	Digital Comp 2	R	%			
AV31	Cool PID	R				
AV32	Heat PID	R	%			
AV33	Clg Supply Reset	R	°F			
AV34	Htg Supply Reset	R	°F			
AV35	Econ PID	R				
AV36	Econ Ramp Count	R	min			
AV37	Econ Lockout Timer	R	min			
AV38	Combustion Blower RPM	R	rpm			
AV39	Raw Mod Gas Valve	R	%			
AV40	Mod Gas Valve	R	%			
AV41	Raw Mod Gas Valve 2	R	%			
AV42	Mod Gas PID	R				
AV43	Electric Preheat PID	R				
AV44	Preheat LAT Probe A	R	°F			
AV45	Preheat LAT Probe B	R	°F			
AV46	Preheat LAT Average	R	°F			
AV47	Network Address	R				

Table 4 - BACnet Points List (Analog Values 2)

Object	Description	Read/Write	Unit	Default	Min	Max
AV48	Morning Cool-Down Spt	R/W	°F	78	55	85
AV49	Morning Warm-Up Spt	R/W	°F	65	50	85
AV50	Preheat OAT Setpoint	R/W	°F	35	10	60
AV51	Preheat LAT Setpoint	R/W	°F	50	35	80
AV52	Duct Static Setpoint	R/W	in. w.c.	1	0.25	5
AV53	Supply Fan Unoccupied Config	R/W		0	0	2
AV54	Supply Fan Occupied Config	R/W		0	0	2
AV55	CO2 Spt	R/W	ppm	900	500	1500
AV56	Defrost Trigger Spt	R/W	°F	32	0	40
AV57	Defrost Trigger Delay	R/W	min	30	1	60
AV58	Defrost Termination Delay	R/W	min	2	1	10
AV59	Occupied Cooling Spt	R/W	°F	74	55	85
AV60	Unoccupied Cooling Spt	R/W	°F	78	55	85
AV61	Supply Cooling Spt	R/W	°F	55	45	65
AV62	Compressor On Time	R/W	sec	180	120	255
AV63	Compressor Off Time	R/W	sec	180	60	255
AV64	Compressor Interstage On Delay	R/W	sec	60	30	255
AV65	Compressor Interstage Off Delay	R/W	sec	60	30	255
AV66	Outside Air Temp Lockout	R/W	°F	55	0	65
AV67	Space Cooling Hi Reset	R/W	°F	76	55	85
AV68	Space Cooling Lo Reset	R/W	°F	73	55	85
AV69	Supply Cooling Hi Reset	R/W	°F	57	45	65
AV70	Supply Cooling Lo Reset	R/W	°F	53	45	65
AV71	Sensible Econ Spt	R/W	°F	60	40	80
AV72	Econ Lockout Time	R/W	min	2	1	20
AV73	Econ Min Position	R/W	%	15	0	100
AV74	Enthalpy Econ Spt	R/W	Btu/lb.	20	15	25
AV75	Comparative Econ Spt	R/W	Btu/lb.	1	1	5
AV76	Mixed Air Spt	R/W	°F	52	50	80
AV77	Occupied Heating Spt	R/W	°F	70	55	85
AV78	Unoccupied Heating Spt	R/W	°F	65	55	85
AV79	Supply Heating Spt	R/W	°F	90	55	120
AV80	Heating On Time	R/W	sec	180	120	255
AV81	Heating Off Time	R/W	sec	180	120	255
AV82	Heating Interstage On Delay	R/W	sec	30	30	255
AV83	Heating Interstage Off Delay	R/W	sec	30	30	255
AV84	OA Heating Lockout	R/W	°F	75	50	100
AV85	Space Heating Hi Reset	R/W	°F	72	55	85
AV86	Space Heating Lo Reset	R/W	°F	69	55	85
AV87	Supply Heating Hi Reset	R/W	°F	100	55	120
AV88	Supply Heating Lo Reset	R/W	°F	90	5	120
AV89	Dehum Enable Spt	R/W	% RH	50	40	60
AV90	Suction Temp Spt	R/W	°F	42	38	48
AV91	MHGRH Purge Time	R/W	sec	120	60	240
AV92	MHGRH Purge Period	R/W	min	60	1	120
AV93	Cooling Head Pressure 1 Spt	R/W	psig	340	250	475
AV94	Cooling Head Pressure 1 Spt	R/W	psig	340	250	475
AV95	Dehum Head Pressure 1 Spt	R/W	psig	390	250	475
AV96	Dehum Head Pressure 2 Spt	R/W	psig	390	250	475
AV97	Condenser Valve Min Position	R/W	%	0	0	100
AV98	Exhaust Fan Min Position	R/W	%	33	0	100
AV99	Building Pressure Spt	R/W	in. w.c.	0.01	-.1	.1



Table 5 - BACnet Points List (Analog Values 3)

Object	Description	Read/Write	Unit	Default	Min	Max
AV100	Heat Wheel Min Run	R/W	sec	1	1	60
AV101	Heat Wheel Defrost Spt	R/W	°F	25	0	35
AV102	Heat Wheel Defrost Time	R/W	sec	120	15	255
AV103	Heat Wheel Defrost Period	R/W	min	30	5	120
AV104	Outside Air Flow Spt	R/W	cfm	0	0	15000
AV105	Outside Air Flow Max Spt	R/W	cfm	0	0	15000
AV106	Outside Air Flow Min Spt	R/W	cfm	0	0	15000
AV107	Dehum Lockout Temp	R/W	°F	55	35	75
AV108	CAV Fan Position	R/W	%	100	33	100
AV109	Supply Fan Max	R/W	%	100	33	100
AV110	SF Cool Min Position	R/W	%	33	33	100
AV111	SF Deadband	R/W	°F	4	2	10
AV112	VAV MCD Time	R/W	min	30	5	60
AV113	VAV MWU Time	R/W	min	30	5	60
AV114	Space Temperature	R	°F			
AV115	Space Relative Humidity	R	% RH			

Table 6 - BACnet Points List (Binary/Relay Values 1)

Object	Description	Read/Write	Default	Min	Max
BV0	Economizer	R		False	True
BV1	Heat Wheel	R		False	True
BV2	Exhaust Fan	R		False	True
BV3	Comp 2	R		False	True
BV4	Comp 1	R		False	True
BV5	Supply Fan Command	R		False	True
BV6	Occupancy Status	R		False	True
BV7	Supply Fan Status	R		False	True
BV8	Emergency Shutdown Status	R		False	True
BV9	Water Flow Status	R		False	True
BV10	Clogged Filter Status	R		False	True
BV11	Comp 2 2nd Step	R		False	True
BV12	Comp 1 2nd Step	R		False	True
BV13	Heat Stage 4	R		False	True
BV14	Heat Stage 3	R		False	True
BV15	Heat Stage 2	R		False	True
BV16	Heat Stage 1	R		False	True
BV17	Dehum	R		False	True
BV18	Cool	R		False	True
BV19	Heat Mode	R		False	True
BV20	Vent Mode	R		False	True
BV21	On Off Mode	R		False	True
BV22	Reversing Valve	R		False	True
BV23	Emergency Shutdown Alarm	R		False	True
BV24	Clogged Filter Alarm	R		False	True
BV25	Supply Fan Alarm	R		False	True
BV26	CO2 Alarm	R		False	True
BV27	Supply Air Temp High Limit	R		False	True
BV28	Supply Air Temp Low Limit	R		False	True
BV29	Outside Air Open	R		False	True
BV30	Outside Air Shorted	R		False	True
BV31	Supply Air Open	R		False	True

Table 7 - BACnet Points List (Binary/Relay Values 2)

<b>Object</b>	<b>Description</b>	<b>Read/Write</b>	<b>Default</b>	<b>Min</b>	<b>Max</b>
BV32	Supply Air Shorted	R		False	True
BV33	Return Air Open	R		False	True
BV34	Return Air Shorted	R		False	True
BV35	Mixed Air Open	R		False	True
BV36	Mixed Air Shorted	R		False	True
BV37	OA Temp Lockout	R		False	True
BV38	Water Flow	R		False	True
BV39	Network Occupy	R/W	False	False	True
BV40	VAV Daytime Heat	R/W	False	False	True
BV41	Network Emergency Shutdown	R/W	False	False	True

## Maintenance and Support

At least once each year, a qualified service technician should check out the HVAC equipment. Supply fans, evaporator coils and air filters should be inspected monthly.



Periodically during operation, it is necessary to perform routine service checks on the performance of the unit. This includes checking of the airflow, the air filters, condenser water flow and refrigerant charge.

### Replacement Parts

Parts for AAON equipment may be obtained from your local AAON representative. Reference the unit serial number and part number when ordering parts.

AAON  
Warranty, Service and Parts Department  
2424 S. Yukon Ave.  
Tulsa, OK 74107  
Ph: 918-583-2266  
Fax: 918-382-6364  
[www.aon.com](http://www.aon.com)

**Note:** Before calling, technician should have model and serial number of the unit available for the service department to help answer questions regarding the unit and controller.

## **Glossary**

**Occupied Cooling:** [Occupied Cooling Spt] Space temperature cooling setpoint for the occupied mode of operation. Default setpoint is 74°F and range is 55-85°F.

**Unoccupied Cooling:** [Unoccupied Cooling Spt] Space temperature cooling setpoint for the unoccupied mode of operation. Default setpoint is 78°F and range is 55-85°F.

## AAON Touchscreen Mini Controller Startup Form

	Date: _____
Job Name: _____	
Address: _____	
Model Number: _____	
Serial Number: _____	Tag: _____
Startup Contractor: _____	
Address: _____	Phone: _____

Pre Startup Checklist	
Installing contractor should verify the following items:	
1. Is there any visible shipping damage? _____	Yes <input type="checkbox"/> No <input type="checkbox"/>
2. Are the clearances adequate for service and operation? _____	Yes <input type="checkbox"/> No <input type="checkbox"/>
3. Have all electrical connections been tested for tightness? _____	Yes <input type="checkbox"/> No <input type="checkbox"/>

Unit Configuration			
Water-Cooled Condenser _____	<input type="checkbox"/>	Air-Cooled Condenser _____	<input type="checkbox"/>
Water-Source Heat Pump _____	<input type="checkbox"/>	Air-Source Heat Pump _____	<input type="checkbox"/>
Constant Volume Cooling _____	<input type="checkbox"/>	Single Zone VAV Cooling _____	<input type="checkbox"/>
Constant Volume Heating _____	<input type="checkbox"/>	VAV Cooling _____	<input type="checkbox"/>
		Makeup Air _____	<input type="checkbox"/>
Supply Fan Control - VFD <input type="checkbox"/> ECM <input type="checkbox"/>			
Supply Fan Cooling Max Speed _____		Supply Fan Heating Max Speed _____	
Supply Fan Cooling Min Speed _____		Supply Fan Heating Min Speed _____	







## **Literature Change History**

April 2016 - First Revision





**AAON**  
**2425 South Yukon Ave.**  
**Tulsa, OK 74107-2728**  
**Phone: 918-583-2266**  
**Fax: 918-583-6094**  
**www.aeon.com**

**AAON Touchscreen Controller**  
**User's Manual**  
**V71810 · Rev. A · 190702**

It is the intent of AAON to provide accurate and current product information. However, in the interest of product improvement, AAON reserves the right to change pricing, specifications, and/or design of its product without notice, obligation, or liability.

Copyright © AAON, all rights reserved throughout the world.  
AAON® and AAONAIRE® are registered trademarks of AAON, Inc., Tulsa, OK.