

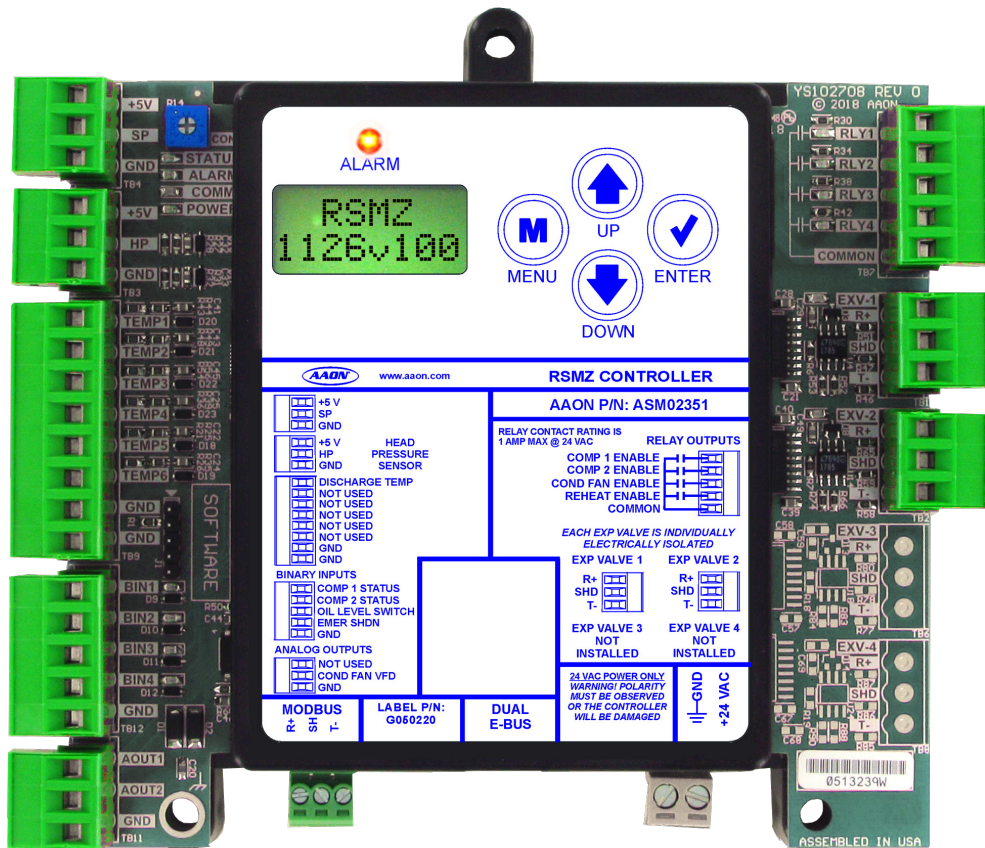

RSMZ Technical Guide



RSMZ REVISION LOG

REVISION & DATE	CHANGE
Rev. A June 10, 2021	Original

RSMZ PARTS REFERENCE

PART DESCRIPTION	PART NUMBER
RSMZ Module	ASM02351
VCCX2 Controller	ASM01698
Subcool Monitor Module	ASM02350
Reheat Expansion Module	ASM01687
EBC E-BUS Cable Assembly E-BUS Power & Comm 1.5 ft., 3 ft., 10 ft., 25 ft., 50 ft., 75 ft., 100 ft., 150 ft., 250 ft., and 1000 ft. Spool	G029440 (1.5 ft.), G012870 (3 ft.), G029460 (10 ft.), G045270 (25 ft.), G029510 (50 ft.), G029530 (75 ft.), G029450 (100 ft.), G029470 (150 ft.), V36590 (250 ft.), G018870 (SPOOL)
E-BUS Adapter Hub with 1.5 ft.. E-BUS Cable	ASM01635
E-BUS Adapter Board	ASM01878



www.aaon.com

**All manuals are also available for download from
www.aaon.com/controlsmanuals.**

AAON
2425 South Yukon Ave.
Tulsa, OK 74107-2728
www.aaon.com
Factory Technical Support Phone: 918-382-6450
AAON® Controls Support: 866-918-1100
It is the intent of AAON® to provide accurate and current product information. However, in the interest of product improvement, AAON® reserves the right to change pricing, specifications, and/or design of its product without notice, obligation, or liability.

AAON P/N: G081900, Rev. A
Copyright June 2021 © AAON. All rights reserved throughout the world.
AAON® and AAONNAIRE® are registered trademarks of AAON, Inc., Tulsa, OK.
BACnet® is a registered trademark of ASHRAE Inc., Atlanta, GA.
Danfoss VFD® is a registered trademark of Danfoss Commercial Compressors, S.A., Tallahassee, FL
AAON® assumes no responsibility for errors or omissions in this document.

OVERVIEW	5
RSMZ Overview	5
RSMZ Dimensions	6
INSTALLATION AND WIRING	7
Electrical and Environmental Requirements	7
RSMZ Module and Subcool Monitor Input/Output Maps	8
WIRING	9
RSMZ Inputs Wiring - Modules 1, 2, 4, and 5	9
RSMZ Outputs Wiring - Modules 1, 2, 4, and 5	10
RSMZ Inputs Wiring - Modules 3 and 6	11
RSMZ Outputs Wiring - Modules 3 and 6	12
Reheat Expansion Module	13
Subcool Monitor Module	14
SEQUENCE OF OPERATIONS.....	15
Modes of Operation	15
Alarms	16
Alarm Faults	17
Alarm Lockouts	18
Subcool Monitor Module Operation	19
LCD SCREENS	20
LCD Display Screen and Navigation Keys.....	20
RSMZ LCD SCREENS	21
Main Screens Map	21
Module Screens	22
System Status Screens.....	23
Sensor and Setpoint Status Screens	24
Alarm Warnings and Alarm Faults Screens	25
Alarm Lockouts	26
Danfoss Menu Screens.....	27
SUBCOOL MONITOR LCD SCREENS	29
Main Screens Map and Subcool Screens.....	29
Circuit Status and Alarm Screens	30
Setpoint Screens.....	31
APPENDIX A: TROUBLESHOOTING.....	32
RSMZ LED Diagnostics	32
Subcool Monitor LED Diagnostics	33
Reheat Expansion Module LED Diagnostics	34
Temperature Sensor Testing	35
Liquid Line and Head Pressure Transducer.....	36
APPENDIX B: DANFOSS VFD	37
Parameter Configurations	37
APPENDIX C: SYSTEM CONFIGURATION	38
Module and Condenser Configuration	38

FIGURES

Figure 1:	RSMZ Dimensions	6
Figure 2:	RSMZ Inputs Wiring - Modules 1, 2, 4, and 5	9
Figure 3:	RSMZ Outputs Wiring - Modules 1, 2, 4, and 5	10
Figure 4:	RSMZ Inputs Wiring - Modules 3 and 6	11
Figure 5:	RSMZ Outputs Wiring - Modules 3 and 6	12
Figure 6:	Reheat Expansion Module Wiring	13
Figure 7:	Subcool Monitor Module Wiring	14
Figure 8:	LCD Display and Navigation Keys	20
Figure 9:	RSMZ LED Locations	32
Figure 10:	Subcool Monitor LED Locations	33
Figure 11:	Reheat Expansion Module LEDs	34
Figure 12:	RSMZ Module Configuration	38
Figure 13:	RSMZ Prism 2 Condenser Configuration	38

TABLES

Table 1:	Electrical and Environmental Requirements	7
Table 2:	RSMZ Inputs and Outputs	8
Table 3:	Subcool Monitor Inputs and Outputs	8
Table 4:	Reheat Expansion Module Outputs	8
Table 5:	Navigation Key Functions	20
Table 6:	Editing Key Functions	20
Table 7:	STATUS LED Blink Codes	32
Table 8:	0-5V Temperature Sensor - Voltage and Resistance for Type III Sensors	35
Table 9:	0-667 psi Transducer Chart	36
Table 10:	Danfoss VFD Parameter Configurations	37

RSMZ Features & Applications

The Refrigerant System Module for VFD Compressors (RSMZ) monitors and controls one refrigeration circuit of the HVAC unit. The RSMZ is used on RZ units and on RN-E units with Danfoss compressors. The module is designed for R410-A refrigerant.

The RSMZ is connected to an AAON unit controller. Three or six RSMZ Modules can be connected, depending on the size of the system. There are two E-BUS expansion ports which allow the use of communicating sensors and the E-BUS Modules. There is a MODBUS terminal block which allows wiring to the Reheat Expansion Module or VFD Compressor.

The RSMZ provides four analog inputs, four binary inputs, four relays, and two analog outputs. See **Figures 2 through 5, pages 9 through 12** for wiring.

The RSMZ Module provides the following:

- Modulates the compressors to satisfy the Suction Coil (Saturated) Temperature. The Suction Coil (Saturated) Temperature Setpoint is reset by the AAON unit controller to maintain the Supply Air Temperature during Cooling Mode. During Dehumidification Mode, it controls the compressors to the Suction (Saturation) Temperature Setpoint.
- Modulates the condenser fan or valve to maintain the Head Pressure Setpoint.
- Monitors the performance of the DMQ Universal Superheat Controller/Sensor (USHX) to maintain the Superheat Setpoint of each evaporator coil.
- Provides alarms and safeties for the compressor and condenser operation.
- Provides a 2 x 8 LCD character display and four buttons that allow for status of system operation, system setpoints, system configurations, sensors, alarms, and to change the module's address, if necessary.

OVERVIEW

RSMZ Dimensions

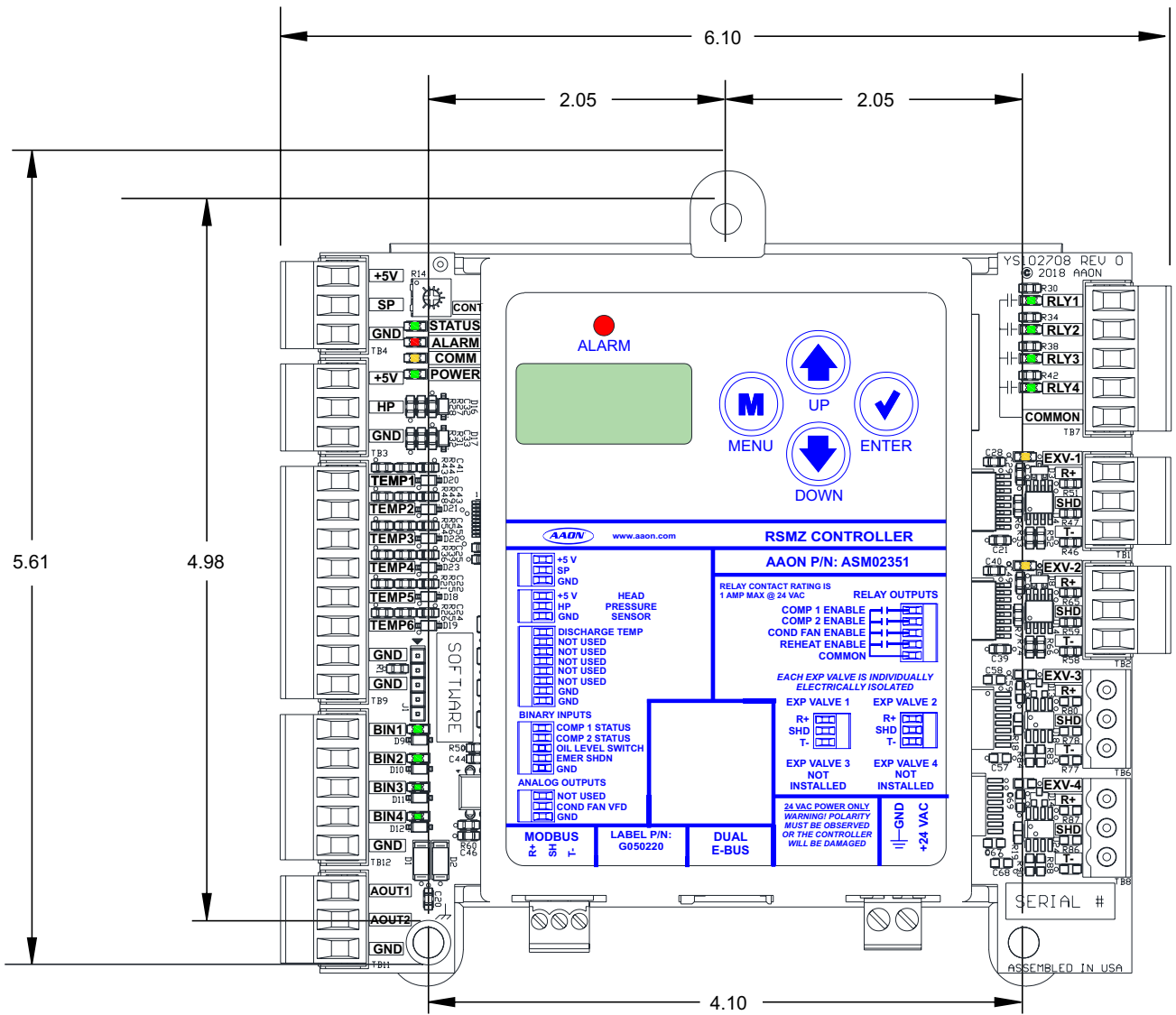

Note: All Dimensions are in inches.

Note: Depth is 1.50 inches.

Figure 1: RSMZ Dimensions

General

Correct wiring of the AAON unit controller and its modules is the most important factor in the overall success of the controller installation process. The AAON unit controller and modules are installed and wired at the AAON factory. Some of the following information may not apply to your installation if it was pre-wired at the factory. However, if troubleshooting of the controller or modules is required, it is a good idea to be familiar with the system wiring.

Wiring

The modules must be connected to an 18-30 VAC power source of the proper size for the calculated VA load requirements. All transformer sizing should be based on the VA ratings listed in **Table 1, this page.**

Control Device	Voltage	VA Load	Operating Temperature	Humidity (Non-Condensing)
RSMZ, Subcool Monitor, and Reheat Expansion Modules	18-30 VAC	18	-22°F to 158°F -30°C to 70°C	0-95% RH
	Inputs		Resistive Inputs require 10KΩ Type III Thermistor	
	Outputs		24 VAC Inputs provide 4.7kΩ Load	
		Relay Outputs: 1 amp maximum per output.		

Table 1: Electrical and Environmental Requirements

NOTE: If the temperature at the module is below -22°F (-30°C), the display refresh rate could be less responsive.

WARNING: When using a single transformer to power more than one controller or expansion module, the correct polarity must always be maintained between the boards. Failure to observe correct polarity will result in damage to the unit controller, RSMZ, and any associated module.

Please carefully read and apply the following information when wiring the unit controller, RSMZ, and any associated module.

1. All wiring is to be in accordance with local and national electrical codes and specifications.
2. All 24 VAC wiring must be connected so that all ground wires remain common. Failure to follow this procedure can result in damage to the controller and connected devices.
3. Minimum wire size for 24 VAC wiring should be 18-gauge.
4. Minimum wire size for all sensors should be 24-gauge. Some sensors require two-conductor wire and some require three-or four-conductor wire.
5. Minimum wire size for 24 VAC thermostat wiring should be 22-gauge.
6. Be sure that all wiring connections are properly inserted and tightened into the terminal blocks. Do not allow wire strands to stick out and touch adjoining terminals which could potentially cause a short circuit.
7. When communication wiring is to be used to interconnect AAON unit controllers together or to connect to other communication devices, all wiring must be plenum-rated, minimum 18-gauge, two-conductor, twisted-pair with shield. AAON can supply communication wire that meets this specification and is color coded for the network or local loop. Please consult your AAON distributor for information. If desired, Belden #82760 or equivalent wire may also be used.
8. Before applying power to the AAON unit controller, RSMZs, and any associated modules, be sure to recheck all wiring connections and terminations thoroughly.

Powering Up

When the controller and modules are first powered up, the POWER LED should light up and stay on continuously. If it does not light up, check to be sure that you have 24 VAC connected to the controller, that the wiring connections are tight, and that they are wired for the correct polarity. The 24 VAC power must be connected so that all ground wires remain common. If after making all these checks, the POWER LED does not light up, please contact AAON Controls Support for assistance.

INSTALLATION AND WIRING

RSMZ Module and Subcool Monitor Input/Output Maps

Input/Output Maps

See **Table 2, this page** for the RSMZ Module inputs and outputs, **Table 3, this page** for Subcool Monitor Module inputs and outputs, and **Table 4, this page** for the Reheat Expansion Module inputs and outputs.

RSMZ MODULE	
Analog Inputs	
1	Head Pressure Transducer (HP)
2	Discharge Temperature Sensor (TEMP1)
Binary Inputs	
1	Compressor 1 Status (BI1)
2	Compressor 2 Status (BI2)
3	Oil Level Switch (BI3)
4	Emergency Shutdown (BI4)
Analog Outputs (0-5 VDC)	
1	Not Used (AO1)
2	Condenser Fan VFD (AO2)
Relay Outputs (24 VAC)	
1	Compressor 1 Enable (RLY1)
2	Compressor 2 Enable (RLY2)
3	Condenser Fan Enable (RLY3)
4	Reheat Enable (RLY4)
DMQ USHX Communication Terminals	
1	Expansion Valve 1 (EXV-1)
2	Expansion Valve 2 (EXV-2)
3	Not Installed (EXV-3)
4	Not Installed (EXV-4)
Communication Terminals	
DUAL E-BUS	2 EBC E-BUS Ports
MODBUS	MODBUS Communication Terminal Block

Table 2: RSMZ Inputs and Outputs

SUBCOOL MONITOR MODULE	
Analog Inputs	
1	Liquid Line Pressure Transducer 1 (SP-1)
2	Liquid Line Pressure Transducer 2 (HP-1)
3	Liquid Line Pressure Transducer 3 (SP-2)
4	Not Used
Temperature Inputs	
1	Liquid Line Temperature 1 (TEMP1)
2	Liquid Line Temperature 2 (TEMP2)
3	Liquid Line Temperature 3 (TEMP3)
Communication Terminals	
DUAL E-BUS	2 E-BUS Ports

Table 3: Subcool Monitor Inputs and Outputs

REHEAT EXPANSION MODULE	
Analog Output	
1	HGR Valve
Binary Input (24 VAC)	
1	Reheat Enable Input
Communication Terminals	
COM	Communication Terminal Block

Table 4: Reheat Expansion Module Outputs

RSMZ Inputs Wiring - Modules 1, 2, 4, and 5

RSMZ Input Wiring

The RSMZ monitors and controls one refrigeration circuit of the HVAC unit. The RSMZ is used on RZ units and on RN-E units with Danfoss compressors. The module is designed for R410-A refrigerant.

The RSMZ is connected to the AAON unit controller. Three or six RSMZ Modules can be connected, depending on the size of the system. There are two E-BUS Expansion Ports which allow the use of communicating sensors and E-BUS Modules. There is a MODBUS terminal block which allows wiring to the Reheat Expansion Module or VFD Compressor.

The RSMZ must be connected to an 18-30 VAC power source. When wiring the RSMZ, its relay outputs must be wired as wet contacts (connected to 24 VAC). See **Figure 2, this page** for RSMZ input wiring for modules 1, 2, 4, and 5.

WARNING: Observe Polarity! All boards must be wired with GND-to-GND and 24 VAC-to-24 VAC. Failure to observe polarity will result in damage to one or more of the boards.

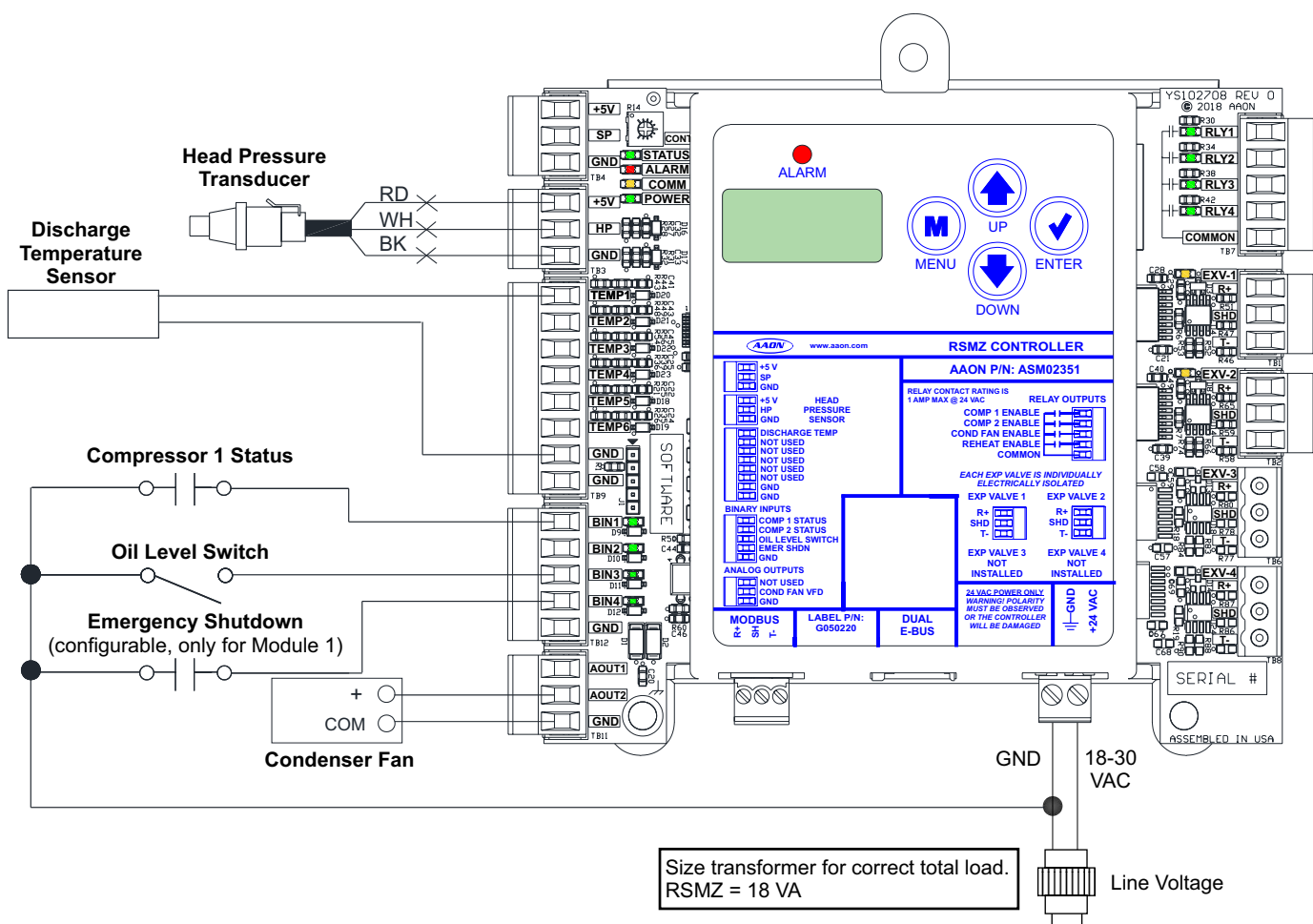

Figure 2: RSMZ Inputs Wiring - Modules 1, 2, 4, and 5

WIRING

RSMZ Outputs Wiring - Modules 1, 2, 4, and 5

RSMZ Output Wiring

See Figure 3, this page for RSMZ outputs wiring for modules 1, 2, 4, and 5.

WARNING: Observe Polarity! All boards must be wired with GND-to-GND and 24 VAC-to-24 VAC. Failure to observe polarity will result in damage to one or more of the boards.

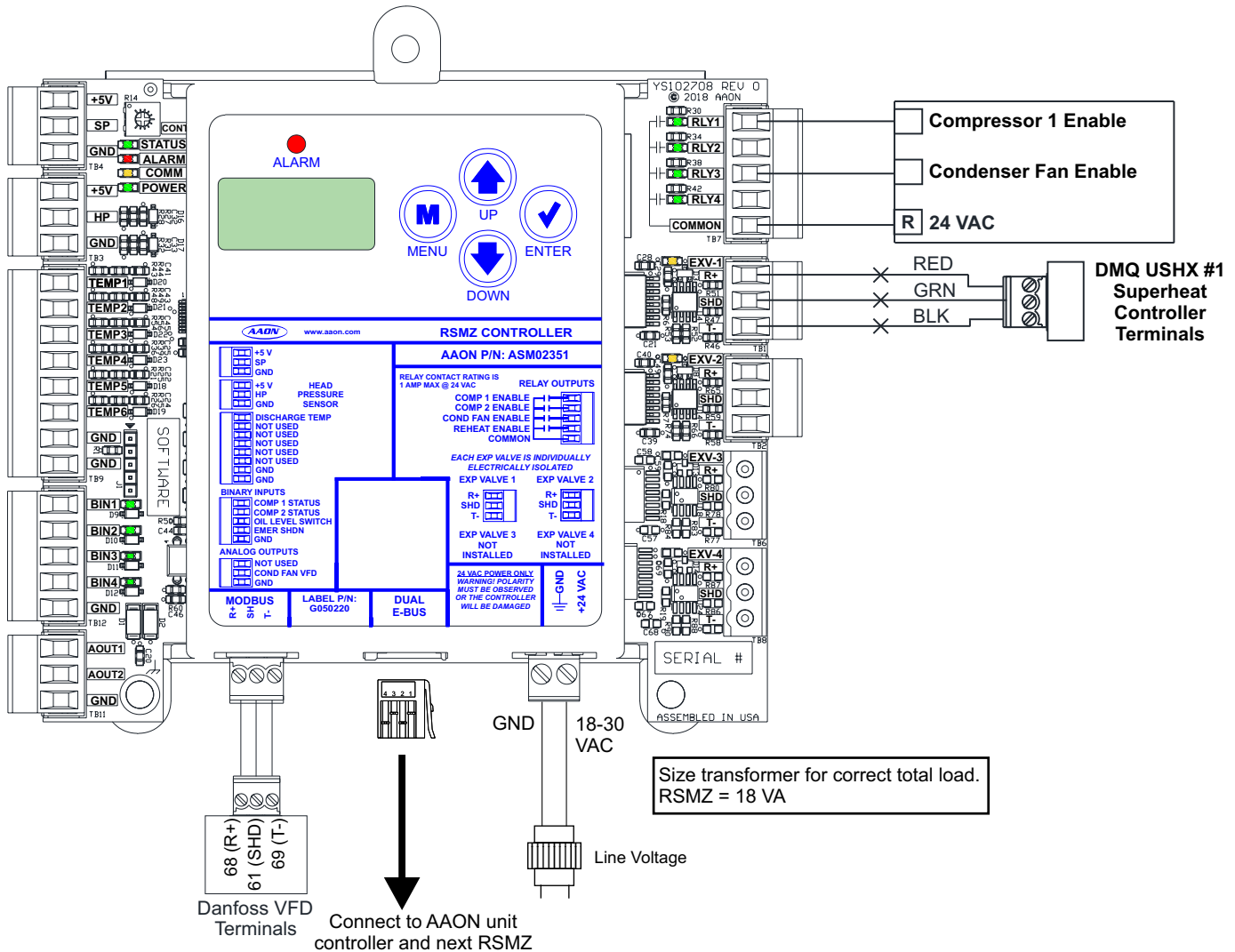

Figure 3: RSMZ Outputs Wiring - Modules 1, 2, 4, and 5

RSMZ Inputs Wiring - Modules 3 and 6

RSMZ Input Wiring

See Figure 4, this page for RSMZ outputs wiring for modules 3 and 6.

WARNING: Observe Polarity! All boards must be wired with GND-to-GND and 24 VAC-to-24 VAC. Failure to observe polarity will result in damage to one or more of the boards.

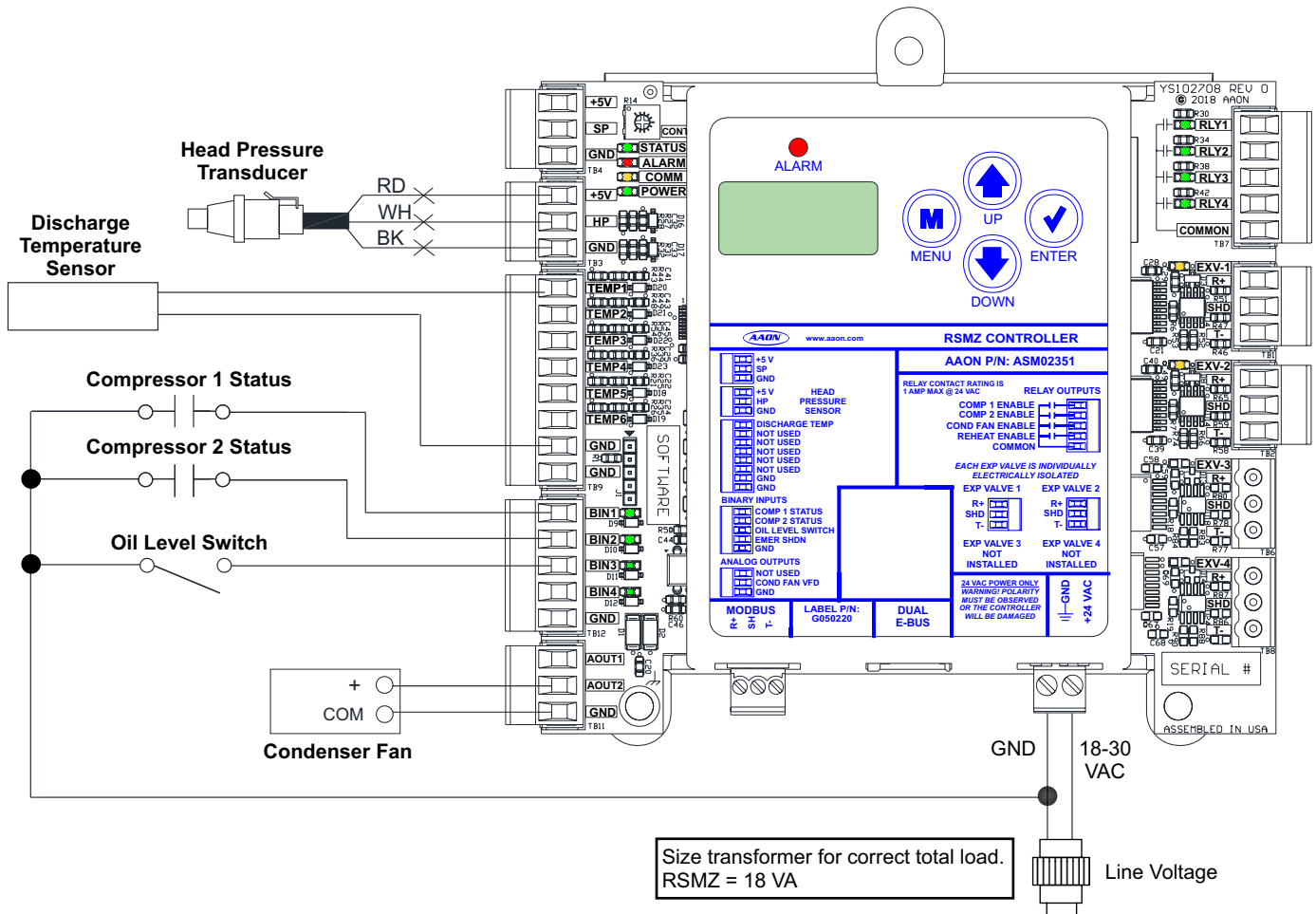

Figure 4: RSMZ Inputs Wiring - Modules 3 and 6

WIRING

RSMZ Outputs Wiring - Modules 3 and 6

RSMZ Output Wiring

See Figure 5, this page for RSMZ outputs wiring for modules 3 and 6.

WARNING: Observe Polarity! All boards must be wired with GND-to-GND and 24 VAC-to-24 VAC. Failure to observe polarity will result in damage to one or more of the boards.

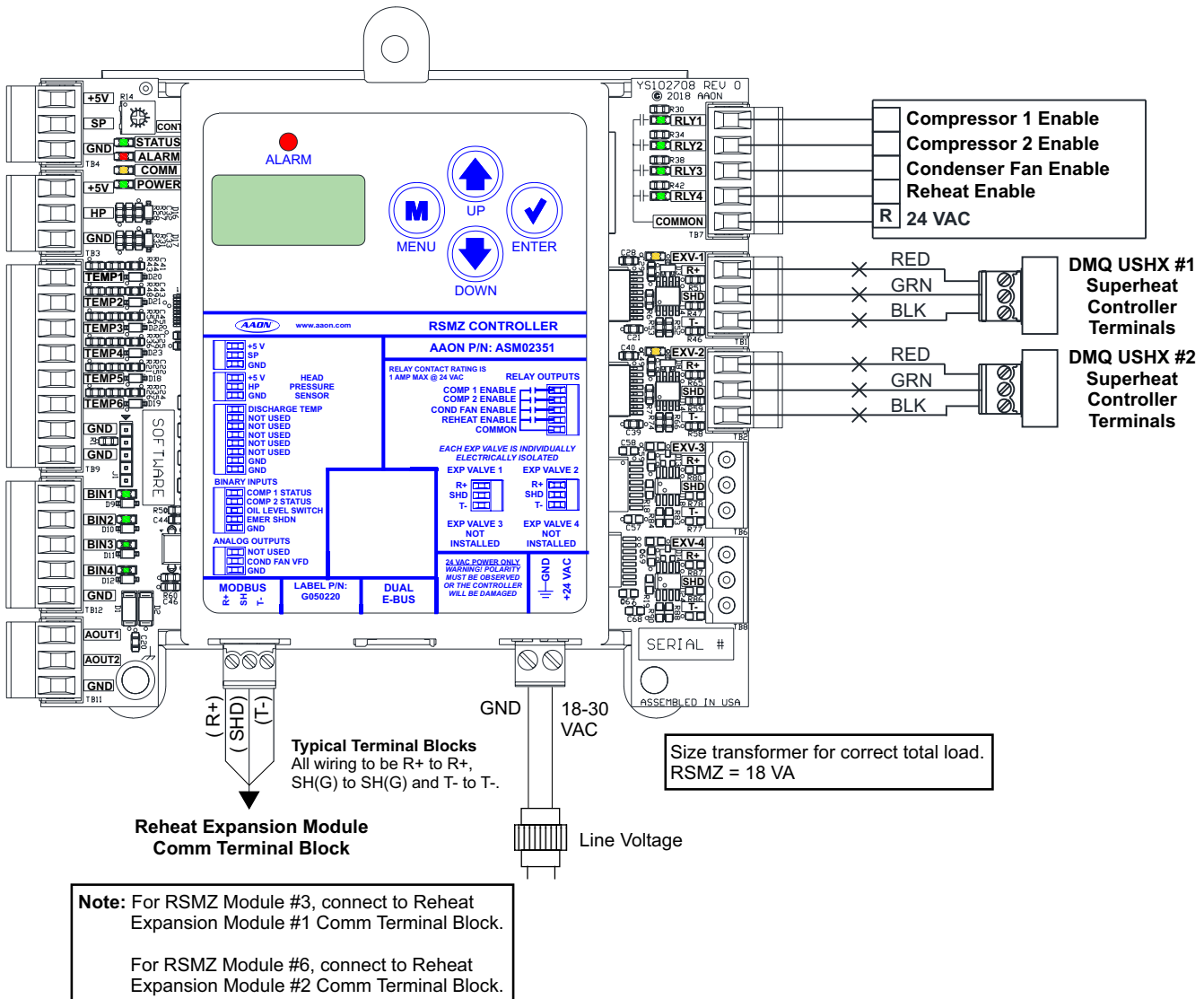

Figure 5: RSMZ Outputs Wiring - Modules 3 and 6

Reheat Expansion Module

Reheat Expansion Module Wiring

The Reheat Expansion Module connects to the RSMZ Communication Terminal Block. One or two Reheat Expansion Modules are used per system.

The Reheat Expansion Module must be connected to an 18-30 VAC power source. See **Figure 6, this page** for wiring.

NOTE: Please refer to the *MHGRV-X Technical Guide* for more information.

WARNING: Observe Polarity! All boards must be wired with GND-to-GND and 24 VAC-to-24 VAC. Failure to observe polarity will result in damage to one or more of the boards.

Size transformer for correct total load.
Reheat Expansion Module = 18 VA

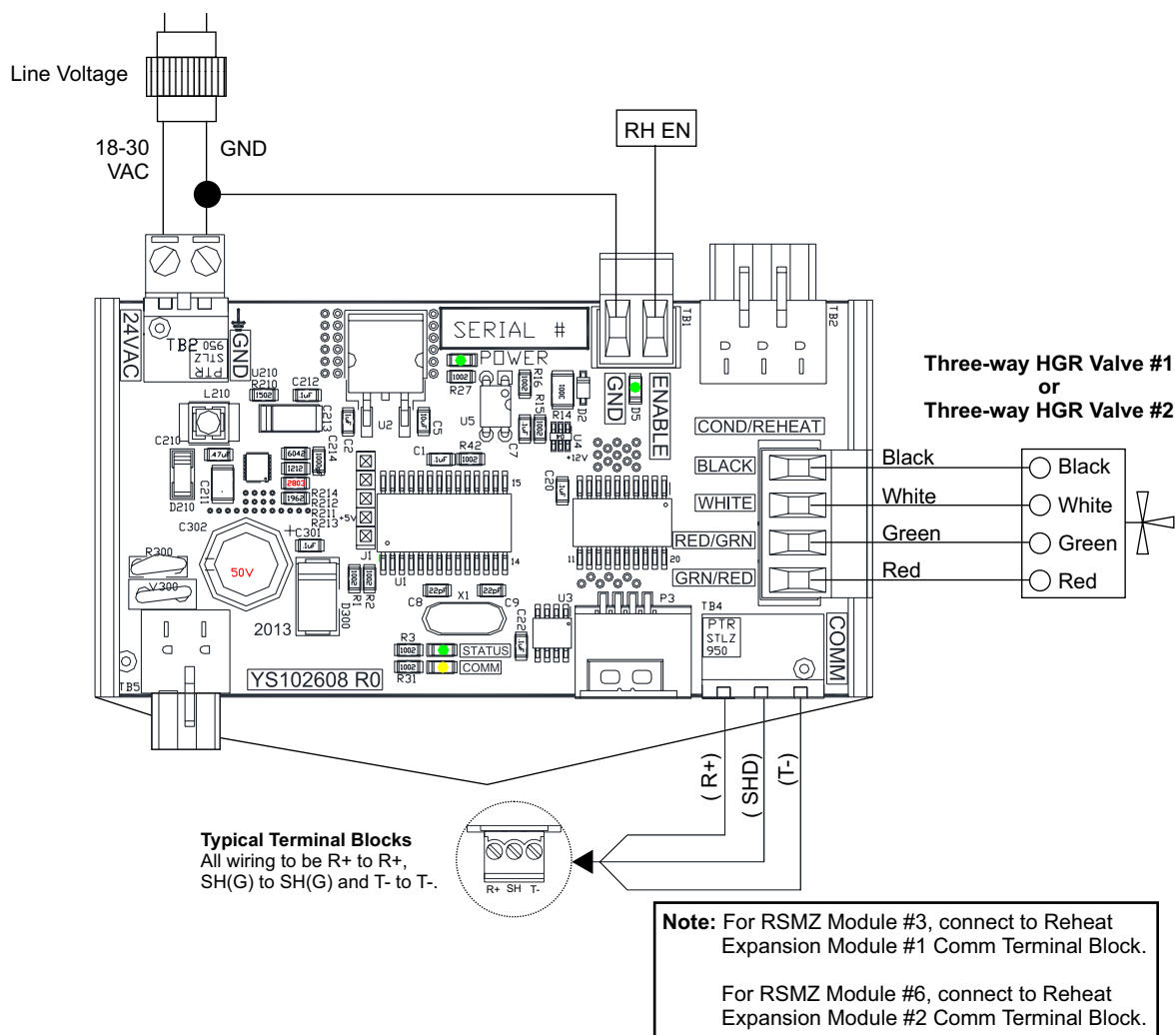

Figure 6: Reheat Expansion Module #1 or #2 Wiring

WIRING

Subcool Monitor Module

Subcool Monitor Module Wiring

The use of the Subcool Monitor Module is optional. The Subcool Monitor Module reads the Liquid Line Temperature Sensors to calculate subcooling. This module can be configured to work with R410-A, R22, and R134a refrigerant and can also be configured for the following pressure transducers—250 psi, 500 psi, and 667 psi.

The Subcool Monitor Module is connected to the AAON unit controller. One or two Subcool Monitor Modules can be connected, depending on the size of the system.

The Subcool Monitor Module contains a 2 x 8 LCD character display and four buttons that allow for status and alarm display.

The Subcool Monitor Module must be connected to an 18-30 VAC power source.

See Figure 7, this page for wiring.

WARNING: Observe Polarity! All boards must be wired with GND-to-GND and 24 VAC-to-24 VAC. Failure to observe polarity will result in damage to one or more of the boards.

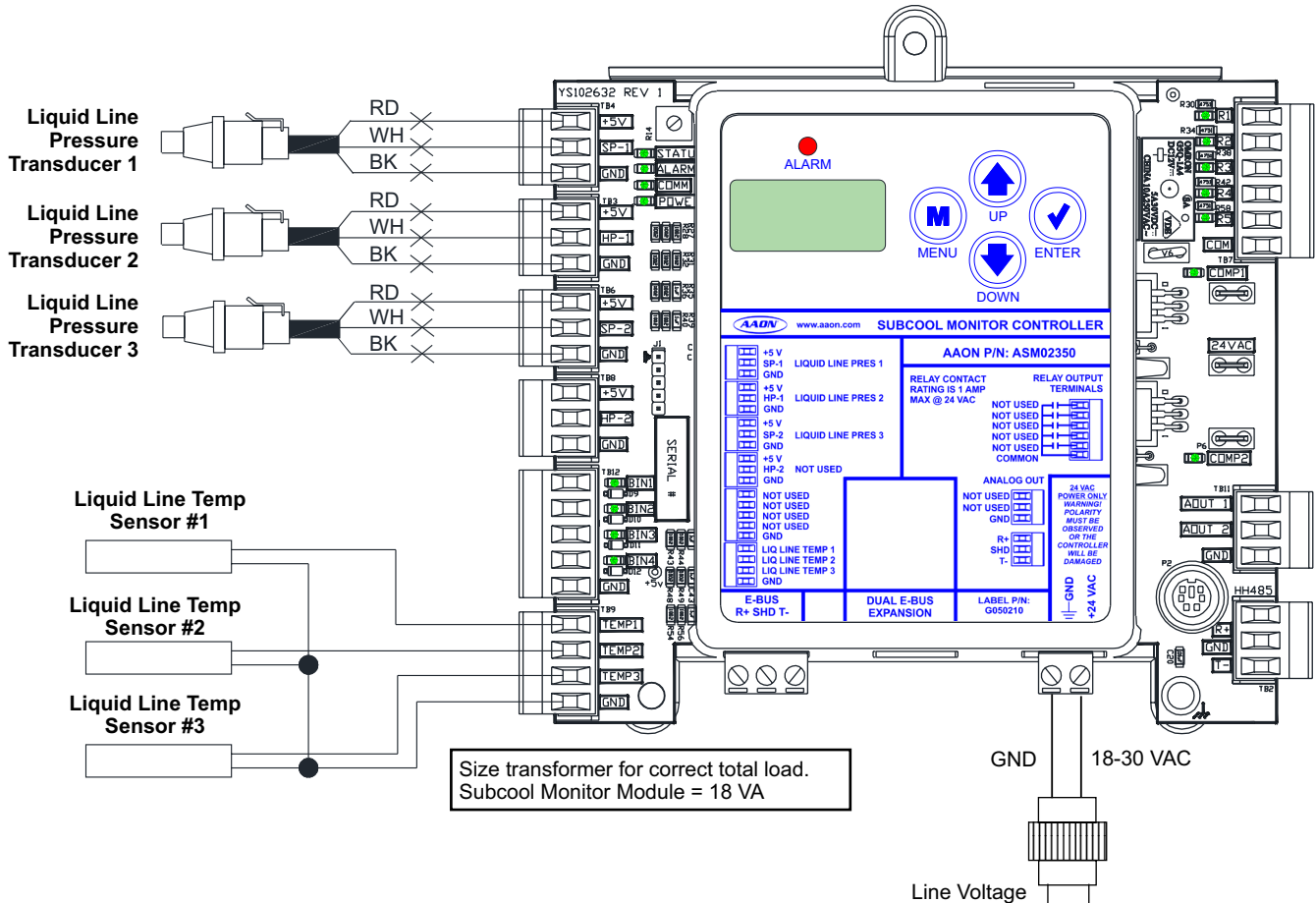

Figure 7: Subcool Monitor Module Wiring

Overview

The RSMZ may be configured to operate as any one of six possible modules in the control system. This configuration automatically adjusts depending on the address of each module. All systems will consist of either three modules or six modules.

RSMZ control is a three or six circuit cooling system with Reheat. The six circuit system is effectively two, three-circuit systems operating in parallel. There is some overlap of controls to ensure that the two systems operate in the same mode.

Modules at addresses 1, 2, 4, and 5 will each control a variable speed circuit (single Danfoss scroll compressor) and represent half of the evaporative face. Superheat is controlled by DMQ, and there is no Reheat.

Modules at addresses 3 and 6 have two tandem fixed compressors, full evaporative face through two parallel evaporators interlaced with the variable compressor-controlled circuits. Each Evaporator Superheat is independently controlled by a DMQ. These circuits also have parallel Reheat with a three-way valve to Control Feed to the Reheat coils or the condenser. 100% Reheat is possible.

Sequencing depends on the particular operation—Cooling Mode or Dehumidification Mode.

Modes of Operation

There are three basic modes of operation for this module:

1. Off Mode
2. Cooling Mode
3. Dehumidification Mode

When changing modes, the mode will first be commanded to RSMZ Module 1 and that module will then share the mode change with the other RSMZ Modules so that all modules will operate in the same mode. If RSMZ Module 1 goes off line for any reason, then DX coil operations will be stopped for the entire unit.

Off (Stop) Mode

During Emergency Off Mode, all compressor(s) will immediately stop, regardless of run time.

During regular Off Mode, all compressor(s) will turn off after they have met their minimum run times. The condenser fan will then be disabled and condenser fan control output will be set to 0V. The DX staging sequence will stop and the module status will change to off.

During Off Mode, monitoring continues to provide status information and alarms remain activated unless otherwise indicated.

Cooling Mode

During startup of the Cooling Mode, the RSMZ receives communication from the AAON unit controller to indicate Cooling Mode which is then used to stage on cooling.

In Cooling Mode, the variable speed compressors are staged on together. If additional cooling is needed, the compressors on the tandem circuit will stage on.

Dehumidification Mode

During startup of Dehumidification Mode, the RSMZ receives communication from the unit controller to indicate Dehumidification Mode which is used by the compressor staging sequence.

If the current state is “all compressors are off” for RSMZ Module 3 or 6, dehumidification will begin once the minimum off time has been met for module 3’s or 6’s first compressor (E1/F1), the condenser fan will modulate to the minimum condenser fan output value. Compressor E1/F1 for module 3 or 6 will then be enabled.

If the current state is “compressors A, B, C, and D are active” for modules 1, 2, 4, or 5, the compressors will modulate to the minimum position, wait for the minimum run time to be met, and then will turn off. The compressors will then be disabled and turn off. Once the minimum off time has been met for modules 3 or 6 first compressor (E1/F1), the condenser fan will modulate to the minimum condenser fan output value. Compressor E1/F1 for module 3 or 6 will then be enabled.

If the current state is “all VFD”, and E1/F1 are active, module 3 or module 6 will wait for the minimum off time to be met for module 3 or 6 compressor E2/F2. Compressor E2/F2 will then be enabled.

Alarms

Alarm Detection and Reporting

The RSMZ continuously performs self diagnostics during normal operation to determine if any operating failures have occurred. These failures (alarms) will be reported to the AAON unit controller which allows them to be monitored via a BACnet® Building Automation System or with a user interface.

The following are the available alarm designations with detailed descriptions for the RSMZ.

Alarm Warnings

Low Suction Pressure Warning

Low Suction Pressure will be ignored for the first minute of initial compressor operation. If Suction Pressure is below 95 psig for 20 seconds, the VFD compressor will modulate down 1% per second. This warning will clear once the Suction Pressure rises above 95 psig.

Low Suction Pressure – Startup Warning

The initial compressor on the circuit cannot start unless the Suction Pressure is at least 120 psig. A warning will occur if the circuit is off and the Suction Pressure drops below 120 psig.

High Discharge Pressure – Level 1 Warning

If the Discharge Pressure rises above 540 psig, the condenser fan will be forced to 100%. The VFD compressor will limit the minimum and maximum RPM limits from 1800 rpm to 5400 rpm, according to envelope protection.

High Discharge Pressure – Level 2 Warning

If the Discharge Pressure rises above 575 psig, the VFD compressor will modulate down 1% per second until the Discharge Pressure drops below 475 psig.

Discharge Pressure Not Detected Warning

If the Discharge Pressure Transducer is not detected and a compressor is running, the condenser fan will be forced to 100%.

Danfoss VFD Alarms Warning

If an alarm occurs from the VFD compressor, the Danfoss Alarm Menu screens will show information on what the alarm code is.

The screens break up the alarms into bytes. If a display is not installed on the VFD, these alarm bytes will aid in knowing which specific alarm has occurred.

Parameter 16-90 Alarm Word 1
“DNFSALM1”

Parameter 16-90, alarm bits 0 – 7
“DNFSALM1”, “B1 ###”

Parameter 16-90, alarm bits 8 – 15
“DNFSALM1”, “B2 ###”

Parameter 16-90, alarm bits 16 – 23
“DNFSALM1”, “B3 ###”

Parameter 16-90, alarm bits 24 – 31
“DNFSALM1”, “B4 ###”

Same with Parameter 16-91 Alarm Word 2
“DNFSALM2”

There are two alarm parameters from the VFD 16-90 and 16-91. Each contain 32 different alarms as a binary bitfield, each bit is a specific alarm. Refer to Danfoss “Operating Instructions” “VLT Compressor Drives CDS 302/CDS 303” that is provided with the unit.

High Superheat Warning

A high superheat warning will occur if a compressor is active and the superheat is above 25°F for two minutes or longer.

High Discharge Line Temperature

This sensor is installed for modulating VFD compressors only. If the Discharge Line Temperature rises above 260°F, the VFD compressor will modulate down 1% per second until the Discharge Line Temperature drops below 260°F.

Compressor 1 False Active Warning

This warning will occur if Compressor 1 is not activated and the running verification signal is active for at least 45 seconds. For Danfoss VFD compressors, the running verification is sent from Modbus Communications. For fixed On/Off compressors, the running verification is a binary input signal to the module.

Compressor 2 False Active Warning

This warning will occur if Compressor 2 is not activated and the running verification signal is active for at least 45 seconds. For Danfoss VFD compressors, the running verification is sent from Modbus Communications. For fixed On/Off compressors, the running verification is a binary input signal to the module.

Discharge Line Temp Sensor Not Detected

This warning will occur if the Discharge Line Temperature Sensor is not detected by the module.

Alarm Faults

Low Suction Pressure Fault

Low Suction Pressure will be ignored for the first minute of initial compressor operation. If Suction Pressure is below 95 psig for one minute, the compressor will be turned off and will be retried after five minutes.

Compressor 2 Low Suction Pressure Fault

Low Suction Pressure will be ignored for the first minute of initial compressor operation. For tandem circuits, if both compressors are running and Suction Pressure is below 95 psig for one minute, the second compressor will be turned off and will be retried after five minutes.

Unsafe Suction Pressure Fault

Unsafe Suction Pressure Detection will be ignored for the first 30 seconds of initial compressor operation. If the Suction Pressure drops below 50 psig for five seconds, the compressor(s) will be turned off and will be retried after five minutes.

High Discharge Pressure Fault

On a single compressor circuit, if the Discharge Pressure rises above 600 psig, the compressor will be turned off and will be retried after five minutes. The compressor will not be reactivated until the pressure rises above 475 psig.

Compressor 2 High Discharge Pressure Fault

On a tandem compressor circuit, if the Discharge Pressure rises above 575 psig and both compressors are running, the second compressor will be turned off and will be retried after five minutes.

Compressor 1 Not Running Fault

If Compressor 1 has been activated for at least 45 seconds and the running verification signal is not active, the compressor signal will be turned off and will be retried after five minutes. For Danfoss VFD compressors, the running verification is sent from Modbus Communications. For fixed On/Off compressors, the running verification is a binary input signal to the module.

Compressor 2 Not Running Fault

If Compressor 2 has been activated for at least 45 seconds and the running verification signal is not active, the compressor signal will be turned off and will be retried after five minutes. For fixed On/Off compressors, the running verification is a binary input signal to the module.

Low Superheat Fault

The low superheat detection will be ignored for the first two minutes of initial compressor operation. If the superheat drops below 4°F for two minutes, the compressor signal will be turned off and will be retried after five minutes.

High Discharge Line Temperature

This sensor is installed for modulating VFD compressors only. If the Discharge Line Temperature rises above 260°F, the VFD compressor will modulate down 1% per second until the Discharge Line Temperature drops below 260°F.

If the compressor modulates down to 1800 rpm, the compressor will be turned off and will be retried if the Discharge Line Temperature drops below 150°F and five minutes has lapsed.

DMQ EXV Sensor Not Detected Fault

If the DMQ EXV Superheat Controller is not detected through Modbus communications for one minute, the compressor(s) will be turned off. This fault will be cleared when communication is reestablished.

Communications Loss Fault

If E-BUS communications are lost for at least 15 seconds, the compressor(s) will be turned off. If the module is controlling a Danfoss VFD compressor and the Modbus communication to the Danfoss VFD compressor is lost for at least 15 seconds, the compressor will be turned off. This fault will be cleared when communication is reestablished.

High Superheat Fault

If a compressor is active and the superheat is above 30°F for 10 minutes or longer, the compressor(s) will be turned off and will be retried after five minutes.

High Evaporator Saturation Temperature Fault

On a tandem circuit, both compressors have to be running to trigger a fault. A modulating VFD compressor has to be at 100% to trigger a fault. If the Evaporator Saturation Temperature rises above 59°F for the stage up delay plus two minutes, the compressor will be turned off and will be retried after five minutes.

Alarm Lockouts

Alarm Lockouts

Low/Unsafe Suction Pressure Lockout

If a low Suction Pressure fault or unsafe Suction Pressure fault occurs three times in a two-hour time period, the circuit will be disabled and locked out until the module is reset.

Low Refrigerant Oil Level Lockout

If an oil boost cycle is performed and the oil level is not detected for one minute, the circuit will be disabled and locked out until the module is reset.

High Discharge Pressure Lockout

If a high Discharge Pressure fault occurs three times in a two-hour time period, the circuit will be disabled and locked out until the module is reset.

Low Superheat Lockout

If a low superheat fault occurs three times in a two-hour time period, the circuit will be disabled and locked out until the module is reset.

High Superheat Lockout

If a high superheat fault occurs three times in a two-hour time period, the circuit will be disabled and locked out until the module is reset.

High Evaporating Temperature Lockout

If a high evaporating temperature fault occurs three times in a two-hour time period, the circuit will be disabled and locked out until the module is reset.

High Discharge Line Temperature Lockout

If a high Discharge Line Temperature fault occurs three times in a two-hour time period, the circuit will be disabled and locked out until the module is reset.

Subcool Monitor Module Operation

The Subcool Monitor Module is a monitoring-only module. It is capable of monitoring the subcooling for up to three circuits, simultaneously. The use of the Subcool Monitor Module is optional.

Subcooling Sequence

The Subcool Monitor Module reads and scales all of its six inputs and calculates the saturated suction and subcooling for each configured circuit.

LCD SCREENS

LCD Display Screen and Navigation Keys

LCD Display Screen & Navigation Keys

The LCD display screens and buttons allow you to view status and alarms, and enable force modes. See **Figure 8, this page** and refer to **Table 5 and Table 6, this page** for key functions.

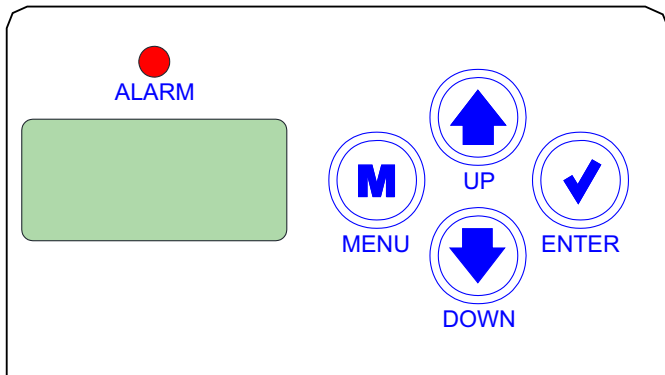

Figure 8: LCD Display and Navigation Keys

Navigation Key	Key Function
MENU 	Use the MENU key to move through screens within Main Menu categories and return to the Main Menu while at other screens.
UP 	Use this key to adjust setpoints and change configurations.
DOWN 	Use this key to adjust setpoints and change configurations.
ENTER 	Use the ENTER key to navigate through the Main Menu Screen categories.

Table 5: Navigation Key Functions

Editing Key	Key Function
UP or DOWN 	Use the UP or DOWN key to enter editing mode on a user-adjustable screen. Edit Mode is indicated by the underscore appearing on the screen. NOTE: Entering Edit Mode will also adjust the value up one (UP key) or down one (DOWN key), so you may have to readjust the value.
ENTER 	Use the ENTER key to move through the digits in the screen when editing a numeric value. An extended press of the ENTER key saves your edits no matter the location of the editing cursor within the digits. Press the ENTER key to save a non-numeric value such as Hi Speed Network.
MENU 	The MENU key cancels editing when in Edit Mode. The screen you were editing will return to its original value and the underscore will disappear. A second press of the MENU key will return you to the Main Menu.

Table 6: Editing Key Functions

RSMZ Main Screens Map

Refer to the following map when navigating through the RSMZ Main Screens. To scroll through the screens, press the <MENU> button.

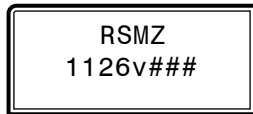

Press to scroll through RSMZ Screens

Press to go to SYSTEM MENU screens.



Press to scroll through SYSTEM MENU screens.

Press to go to SENSOR MENU screens.

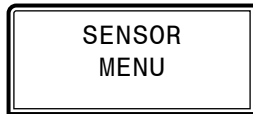

Press to scroll through SENSOR MENU screens.

Press to go to SETPOINT STATUS screens.

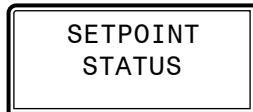

Press to scroll through SETPOINT STATUS screens.

Press to go to ALARM WARNINGS screens.



Press to scroll through ALARM WARNINGS screens.

Press to go to ALARM FAULTS screens.

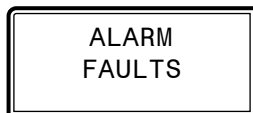

Press to scroll through ALARM FAULTS screens.

Press to go to ALARM LOCKOUTS Screens.



Press to scroll through ALARM LOCKOUTS Screens.

Press to go to DANFOSS MENU screens.



Press to scroll through DANFOSS MENU screens.

Press to go to RSMZ Main Screen.

Module Screens

RSMZ Module Screens

Refer to the following map when navigating through the RSMZ Screens. From the RSMZ Module Screen, press <ENTER> to scroll through the screens.

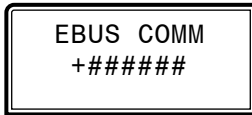
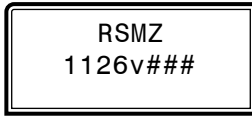

E-BUS COMMUNICATION DIAGNOSTICS
Number of COMM packets received.

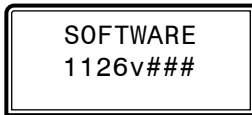

SOFTWARE VERSION

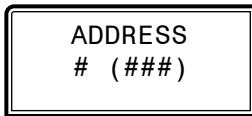

CURRENT BOARD ADDRESS

Configure the address according to which circuit this module represents. If three RSMZ modules—1=A, 2=B, 3=C
If six RSMZ modules—1=A, 2=C, 3=E, 4=B, 5=D, 6=F
Number in parentheses is E-BUS address.
Module 1's address is 177, Module 2's address 178,
Module 3's address is 179, Module 4's address is 180,
Module 5's address is 181, Module 6's address is 182

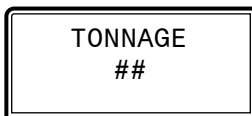

UNIT TONNAGE



MAX SPEED BASED ON UNIT TONNAGE

System Status Screens

Refer to the following map when navigating through the System Status Screens. From the SYSTEM STATUS Screen, press <ENTER> to scroll through the screens.

STATUS
MENU



MODE

SYSTEM MODE
MIN RUN, OFF, COOLING, HEATING, DEHUM, or FORCED



STAGE
#

NUMBER OF STAGES



COMP%
0%

COMPRESSOR STATUS



COND%
0%

CONDENSER STATUS



STAGE UP
0

STAGE UP STATUS



C1 MIN RUN
0

COMPRESSOR 1 MINIMUM RUN TIME



C2 MIN RUN
0

COMPRESSOR 2 RUN TIME



C1 MIN OFF
0

COMPRESSOR 1 MINIMUM OFF TIME



C2 MIN OFF
0

COMPRESSOR 2 MINIMUM OFF TIME

Sensor and Setpoint Status Screens

Sensor Status Screens

Refer to the following map when navigating through the Sensor Status Screens. From the SENSOR MENU Screen, press <ENTER> to scroll through the screens.

SENSOR
MENU



SUPPLY
XX.X°F

SUPPLY AIR TEMPERATURE READING FROM INPUT



SATURATN
XX.X°F

SATURATION TEMPERATURE READING FROM INPUT



DISCHRG
XXX PSIG

DISCHARGE PRESSURE READING FROM INPUT



DISCHRG
XX.X°F

DISCHARGE TEMPERATURE READING FROM INPUT



SUCTION
XXX PSIG

SUCTION PRESSURE READING FROM INPUT



SUPRHEAT
XX.X°F

SUPERHEAT READING FROM TEMPERATURE
SENSOR INPUT

Setpoint Status Screens

Refer to the following map when navigating through the Setpoint Status Screens. From the SETPOINT STATUS Screen, press <ENTER> to scroll through the screens.

SETPOINT
STATUS



SUPPLYSP
XX.X°F

SUPPLY TEMPERATURE SETPOINT



EVAPCLSP
XX.X°F

EVAPORATOR COIL TEMPERATURE SETPOINT



DSCHG SP
XXX PSI

DISCHARGE PRESSURE SETPOINT



SHEAT SP
XX.X°F

SUPERHEAT SETPOINT

Alarm Screens

If an alarm is present, the ALARM LED above the LCD display will light up red and blink. The Alarms will display and scroll automatically from the ALARMS screen when alarms are present.

For detailed alarm descriptions, see **page 16**.



NO WARNINGS

This will be shown if there are no current warnings.

WARNINGS!

This will display if there are active warnings.

- LOW SUCT PRESSURE**—Low Suction Pressure
- LOW SUCT NO START**—Low Suction Pressure - Startup
- HIGH DISCHPSI**—High Discharge Pressure
- DISCHPSI NODETECT**—Discharge Pressure Not Detected
- VFD ALARM**—Danfoss VFD Alarms
- HIGH SUPRHEAT**—High Superheat
- HIGH DISCTEMP**—High Discharge Line Temperature
- C1 FALSE ACTIVE**—Compressor 1 False Active
- C2 FALSE ACTIVE**—Compressor 2 False Active
- DLT NODETECT**—Discharge Line Temperature Sensor Not Detected



NO FAULTS

This will be shown if there are no current faults.

FAULTS!

This will display if there are active faults.

- LOW SUCT PRESSURE**—Low Suction Pressure
- UNSAFE SP**—Unsafe Suction Pressure
- HIGH PSI TRIP**—High Discharge Pressure Trip
- HIGH PSI TRIP C2**—Compressor 2 Fail From High Discharge Pressure
- C1 NO START**—Compressor 1 Not Running
- C2 NO START**—Compressor 2 Not Running
- LOW SUPRHEAT**—Low Superheat
- HIGH DISCTEMP**—High Discharge Line Temperature
- DMQ EXV NODETECT**—DMQ EXV Sensor Not Detected
- COMM TIMEOUT**—Communications Loss
- C2 OFF LOW SUCT**—Compressor 2 Fail From Low Suction Pressure
- HIGH SUPRHEAT**—High superheat
- HIGH EVAPTEMP**—High Evaporator Saturation Temperature

Alarm Lockouts



NO LOCKOUTS

This will be shown if there are no current lockouts.

LOCKOUTS!

This will display if there are active lockouts.

SUCT PSI LOCKOUT—Low/unsafe Suction Pressure

LOW OIL LOCKOUT—Low refrigerant oil level

HIGHDISC PSI L/O—High Discharge Pressure

LOW SH LOCKOUT—Low superheat

HIGH SH LOCKOUT—High superheat

HIGHEVAP LOCKOUT—High evaporating temperature

HIGHDISC TEMP L/O—High Discharge Line Temperature

Danfoss Menu Screens

Refer to the following map when navigating through the Screens. From the DANFOSS MENU Screen, press <ENTER> to scroll through the screens.

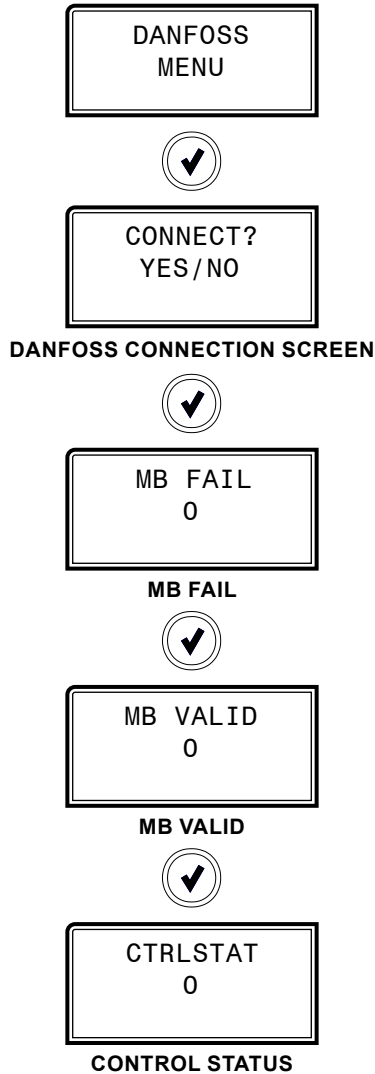

The following status messages may be displayed in the second line:

- DRV STAT
- ENABLED?
- TRIP ERR
- ALT ERR
- TRIPLOCK
- WARNING?
- SPDvsREF
- BUS CTRL
- FREQ LIM
- IN OPER?
- STP/AUTO
- VOLT LMT
- TORQ LMT
- TIME LMT

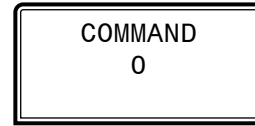

COMMAND STATUS
Command speed to VFD
Range: 0-100%

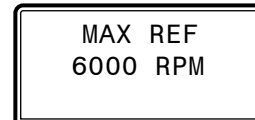

MAX REF RPM

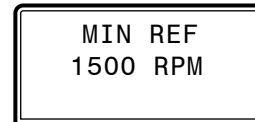

MIN REF RPM

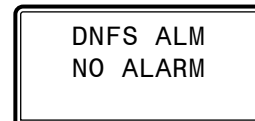

DANFOSS ALARM OR NO ALARM

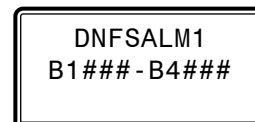

DANFOSS 1 ALARMS B1-B4 CODES

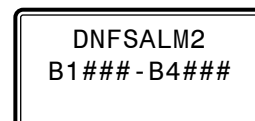

DANFOSS 2 ALARMS B1-B4 CODES



Danfoss Menu Screens

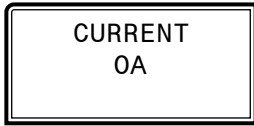

CURRENT OA

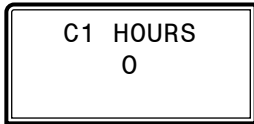

COMPRESSOR 1 HOURS

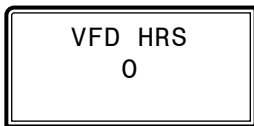

VFD HOURS

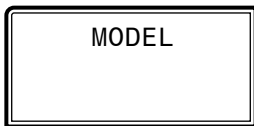

DANFOSS MODEL PART NUMBER

SUBCOOL MONITOR LCD SCREENS

Main Screens Map and Subcool Screens

Main Menu Map

Refer to the following map when navigating through the LCD Main Screens. To scroll through the screens, press the **<MENU>** button.

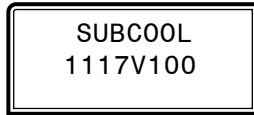

Press to scroll through SUBCOOL screens

Press to go to CIRCUIT 1 screens.

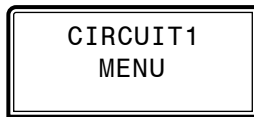

Press to scroll through CIRCUIT 1 screens.

Press to go to CIRCUIT 2 screens.

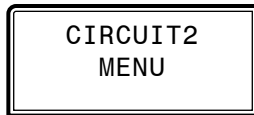

Press to scroll through CIRCUIT 2 screens.

Press to go to CIRCUIT 3 screens.

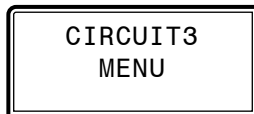

Press to scroll through CIRCUIT 3 screens.

Press to go to ALARMS screens.

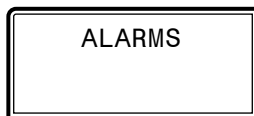

Press to scroll through ALARMS screens.

Press to go to SETPOINT screens.



Press to scroll through SETPOINT screens.

Subcool Screens

Refer to the following map when navigating through the Subcool Monitor Module screens. From the SUBCOOL Screen, press **<ENTER>** to scroll through the screens.

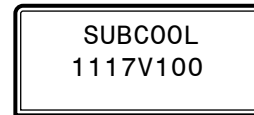

E-BUS COMMUNICATION DIAGNOSTICS
Number of COMM packets received.

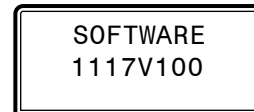

SOFTWARE VERSION

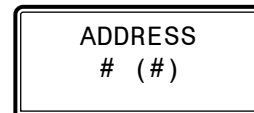

CURRENT BOARD ADDRESS

If there is only one Subcool module the address needs to be set to 1.
If there are two Subcool modules then board address 1 is for the first 3 circuits and address 2 is for the second 3 circuits
Number in parentheses is E-BUS address.
Module 1's address is 169, Module 2's address is 170.



SUBCOOL MONITOR LCD SCREENS

Circuit Status and Alarm Screens

Circuits 1, 2, 3 Status Screens

Refer to the following map when navigating through the Circuit Status Screens. From the CIRCUIT MENU # Screen, press <ENTER> to scroll through the screens.

CIRCUIT #
MENU



SUBCOOL #
XXX.X°F

CURRENT SUBCOOL TEMPERATURE



PRES #
XXX PSIG

LIQUID LINE READING FROM INPUT



SATTEMP #
XXX.X°F

SATURATED LIQUID TEMPERATURE



TEMP #
XXX.X°F

LIQUID LINE TEMPERATURE

Alarm Screen

If an alarm is present, the ALARM LED above the LCD display will light up red and blink. The Alarms will display and scroll automatically from the ALARMS screen when alarms are present.

ALARMS

NO
ALARMS

COMM
TIMEOUT

NO ALARMS

No Alarms will display if there are no alarms.

COMM TIMEOUT

This alarm will display if the Subcool Monitor is not communicating with the AAON unit controller.

Setpoint Screens

Refer to the following map when navigating through the SETPOINT MENU Screens. From the SETPOINT MENU, press <ENTER> to scroll through the screens.

SETPOINT
MENU



ADDRESS
1 (###)

UNIT ADDRESS

Unit Address. Valid range is 1-59. Default is 59.



TMPSCALE

TEMPERATURE SCALING

Fahrenheit or Celsius



REFRGRNT

REFRIGERANT

410-A, 134a, R22



TRNSDCER
PSIG

TRANSDUCER PSIG

250, 500, 667



CIRCUITS
1,2,3

NUMBER OF CIRCUITS

1, 2, 3

APPENDIX A: TROUBLESHOOTING

RSMZ LED Diagnostics

Using RSMZ LEDs to Verify Operation

The RSMZs are equipped with LEDs that can be used to verify operation and perform troubleshooting. See **Figure 9, this page** for the LED locations. The LEDs associated with these inputs and outputs allow you to see what is active without using a voltmeter. The LEDs and their uses are as follows:

STATUS - If the software is running, this LED will blink according to what mode the RSMZ is in. See **Table 7, this page**.

No. of Blinks	STATUS LED
1	Off Mode
2	Cool Mode
3	Heat Mode
4	Reheat Mode
5	Force Mode
Fast Blink	Emergency Shutdown

Table 7: STATUS LED Blink Codes

ALARM (on board and above LCD display) - This red LED will blink when there is an alarm present. The type of alarm will display on the LCD display. The ALARM LED also blinks when the expansion valve is initializing at startup.

COMM - Every time the module receives a valid E-BUS request from the AAON unit controller, this LED will blink on and then off, signifying that it received a valid request and responded.

POWER - This LED will light up to indicate that 24 VAC power has been applied to the module.

Binary Input LEDs

BIN1 - This green LED will light up when Compressor 1 Status contact is closed.

BIN2 - This green LED will light up when Compressor 2 Status contact is closed.

BIN3 - This green LED will light up when the Oil Level Switch is closed.

BIN4 - This green LED will light up when the Emergency Shutdown contact is closed.

Relay LEDs

RLY1 - RLY4 - These green LEDs will light up when the relays are enabled and will stay lit as long as they are active.

RSMZ Stepper Motor Valve LEDs

EXV-1 - This yellow LED will blink to indicate communication to the DMQ. If the LED is on solid that indicates no communication to the DMQ.

EXV-2 - This yellow LED will blink to indicate communication to the DMQ. If the LED is on solid that indicates no communication to the DMQ.

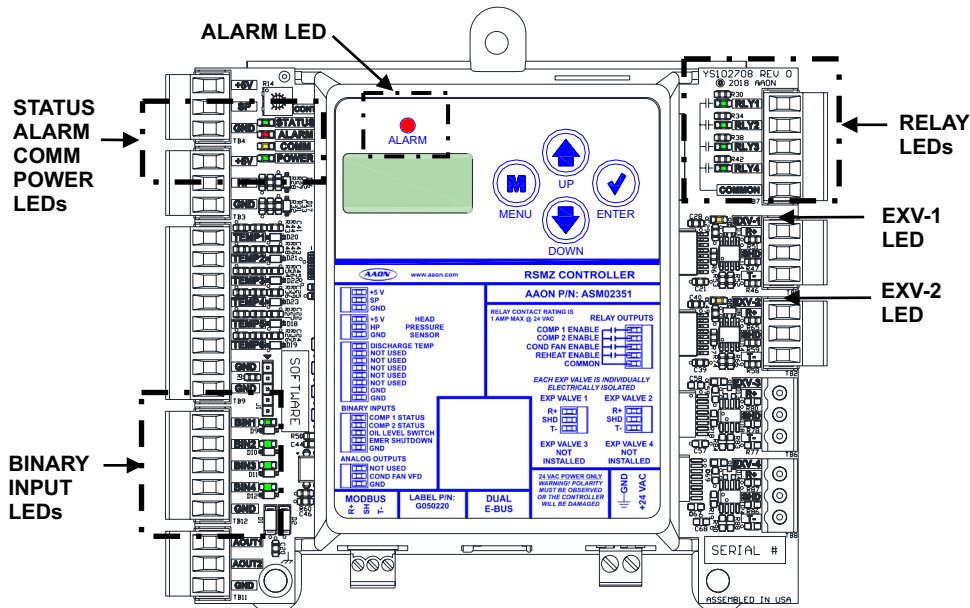

Figure 9: RSMZ LED Locations

Subcool Monitor LED Diagnostics

Using Subcool Monitor Module LEDs to Verify Operation

The Subcool Monitor Module is equipped with LEDs that can be used to verify operation and perform troubleshooting. See **Figure 10, this page** for the LED locations. The LEDs and their uses are as follows:

POWER - This LED will light up to indicate that 24 VAC power has been applied to the module.

COMM - Every time the module receives a valid E-BUS request from the AAON unit controller, this LED will blink on and then off, signifying that it received a valid request and responded.

STATUS - If the software is running, this LED should blink once every 10 seconds.

ALARM (on board) - If the module does not receive communications for more than one minute, this LED will blink.

ALARM (above LCD display) - This red LED will light up and blink when there is an alarm present. The type of alarm will display on the LCD display.

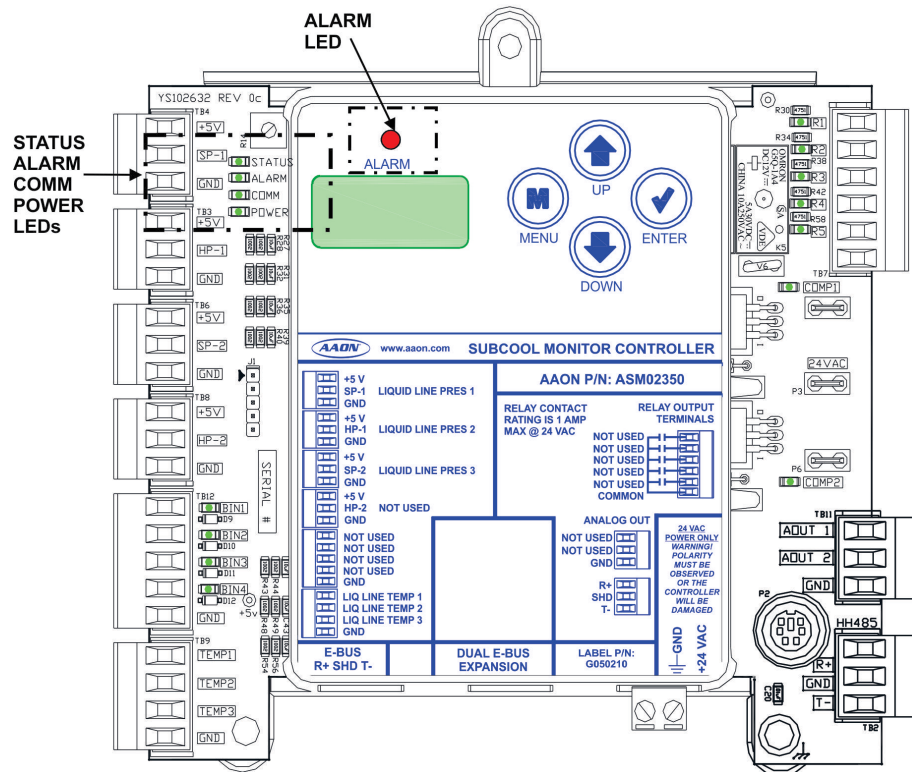

Figure 10: Subcool Monitor LED Locations

APPENDIX A: TROUBLESHOOTING

Reheat Expansion Module LED Diagnostics

LED Diagnostics

The Reheat Expansion Module is equipped with four LEDs that can be used to verify operation and perform troubleshooting.

See **Figure 11, this page** for the LED locations. The LEDs associated with these inputs and outputs allow you to see what is active without using a voltmeter. The LEDs and their uses are as follows:

Operation LEDs

- **POWER:** This green LED will light up to indicate that 24 VAC power has been applied to the Expansion Module.
- **STATUS:** This green LED will light up and blink every 10 seconds according to valve position. One blink per 10%. Example: valve position is 67%. STATUS LED will blink six times every 10 second cycle. The STATUS LED will stay on solid during the two-minute flush cycle. See **Figure 11, this page**.

Communication LED

- **COMM:** This amber LED will light up and blink once for every good packet received. Packets should be sent once every second, so the COMM LED should blink the same, once every second. The COMM LED should blink simultaneously on all modules.

Binary Input LED

- **COMPRESSOR ENABLE:** This green LED will light up when the Reheat is enabled.

LED Troubleshooting

- **“POWER” LED:** When the Reheat Expansion Module is powered up, the POWER LED should light up and stay on continuously. If it does not light up, check to be sure that the power wiring is connected to the board, the connections are tight, and the transformer is powered. If after making all these checks, the POWER LED does not light up, the board is probably defective.
- **“STAT” LED:** When the board is first powered up, the STAT LED will do the following:
 - On for 10 seconds
 - Blinks 30 times
 - Status code repeatedly blinks the indicated valve position every ten seconds

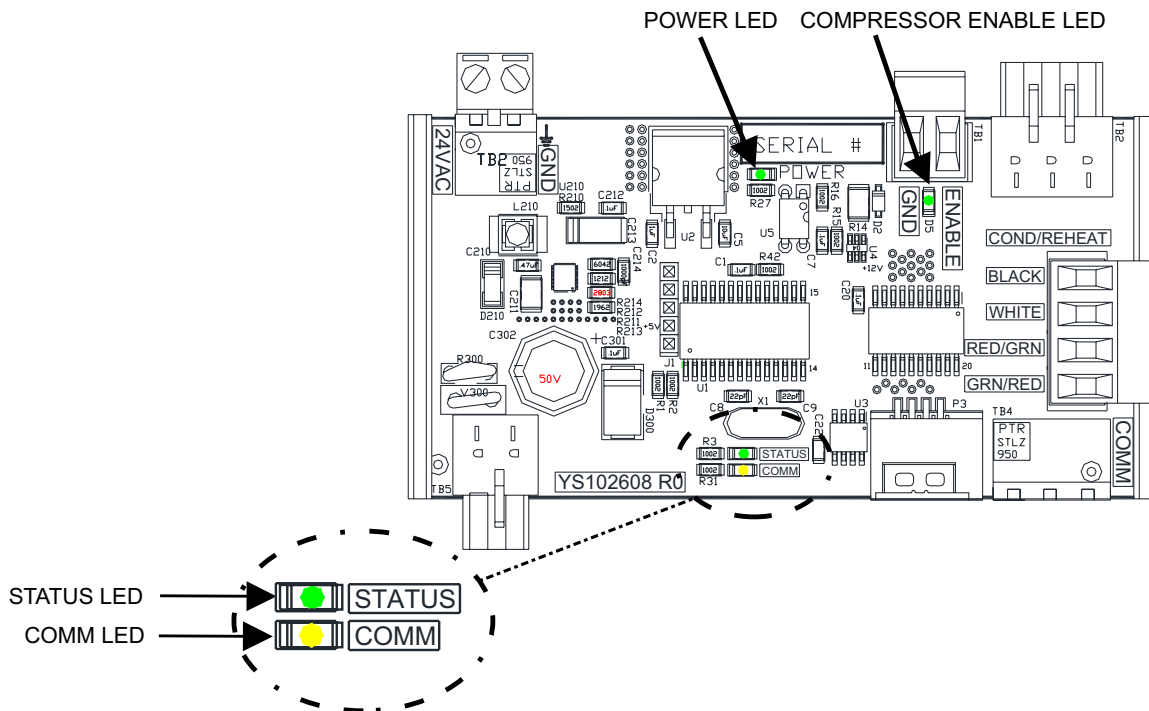

Figure 11: Reheat Expansion Module LEDs

Sensor Voltage and Resistance

The following sensor voltage and resistance table is provided to aid in checking sensors that appear to be operating incorrectly. See **Table 8, this page**. Many system operating problems can be traced to incorrect sensor wiring. Be sure all sensors are wired per the wiring diagrams in this manual.

If the sensors still do not appear to be operating or reading correctly, check voltage and/or resistance to confirm that the sensor is operating correctly per the tables. Please follow the notes and instructions that appear after the chart when checking sensors.

Temperature to Resistance/Voltage Chart							
Temp (°F)	Temp (°C)	Resistance (Ohms)	Voltage @ Input (VDC)	Temp (°F)	Temp (°C)	Resistance (Ohms)	Voltage @ Input (VDC)
-10	-23.3	93333	4.620	72	22.2	11136	2.695
-5	-20.6	80531	4.550	73	22.8	10878	2.665
0	-17.8	69822	4.474	74	23.3	10625	2.635
5	-15	60552	4.390	75	23.9	10398	2.607
10	-12.2	52500	4.297	76	24.4	10158	2.577
15	-9.4	45902	4.200	78	25.6	9711	2.520
20	-6.6	40147	4.095	80	26.7	9302	2.465
25	-3.9	35165	3.982	82	27.8	8893	2.407
30	-1.1	30805	3.862	84	28.9	8514	2.352
35	1.7	27140	3.737	86	30	8153	2.297
40	4.4	23874	3.605	88	31.1	7805	2.242
45	7.2	21094	3.470	90	32.2	7472	2.187
50	10	18655	3.330	95	35	6716	2.055
52	11.1	17799	3.275	100	37.8	6047	1.927
54	12.2	16956	3.217	105	40.6	5453	1.805
56	13.3	16164	3.160	110	43.3	4923	1.687
58	14.4	15385	3.100	115	46.1	4449	1.575
60	15.6	14681	3.042	120	48.9	4030	1.469
62	16.7	14014	2.985	125	51.7	3656	1.369
64	17.8	13382	2.927	130	54.4	3317	1.274
66	18.9	12758	2.867	135	57.2	3015	1.185
68	20	12191	2.810	140	60	2743	1.101
69	20.6	11906	2.780	145	62.7	2502	1.024
70	21.1	11652	2.752	150	65.6	2288	0.952
71	21.7	11379	2.722				

Note: If the voltage is above 5.08 VDC the sensor or wiring is "open." If the voltage is less than 0.05 VDC, the sensor or wiring is shorted.

Table 8: 0-5V Temperature Sensor - Voltage and Resistance for Type III Sensors

APPENDIX A: TROUBLESHOOTING

Liquid Line and Head Pressure Transducer

Liquid Line Pressure Transducer and Head Pressure Transducer Testing 0-667 psi

Liquid Line Pressure Transducer Testing

The Liquid Line Pressure is obtained by using the Liquid Line Pressure Transducer, which is connected into the Liquid Line of the compressor.

Use the voltage column to check the Liquid Line Pressure Transducer while connected to the Subcool Monitor Module. The module must be powered for this test. Read voltage with a meter set on DC volts. Place the positive lead from the meter on the SIG input terminal located on the module. Place the negative lead from the meter on the ground (GND) terminal located adjacent to the SIG terminal on the module. Use a refrigerant gauge set to measure the suction line pressure near where the Liquid Line Pressure Transducer is connected to the discharge line. Measure the voltage at the SIG and GND terminals and compare it to the appropriate chart depending on the refrigerant you are using. If the pressure/voltage readings do not align closely with the chart, your Liquid Line Pressure Transducer is probably defective and will need to be replaced.

Head Pressure Transducer Testing

Use the voltage column to check the Head Pressure Transducer while connected to the RSMZ Module. The module must be powered for this test. Read voltage with a meter set on DC volts. Place the positive lead from the meter on the HP input terminal located on the module. Place the negative lead from the meter on the ground (GND) terminal located adjacent to the HP terminal on the module. Use a refrigerant gauge set to measure the line pressure near where the Head Pressure Transducer is connected to the condenser. Measure the voltage at the HP and GND terminals and compare it to the appropriate chart depending on the refrigerant you are using. If the pressure/voltage readings do not align closely with the chart, your Head Pressure Transducer is probably defective and will need to be replaced.

0-667 psi Transducer Chart			
Voltage	Pressure	Voltage	Pressure
0.5	0	2.6	350
0.6	17	2.7	367
0.7	33	2.8	384
0.8	50	2.9	400
0.9	67	3.0	417
1.0	83	3.1	434
1.1	100	3.2	450
1.2	117	3.3	467
1.3	133	3.4	484
1.4	150	3.5	500
1.5	167	3.6	517
1.6	183	3.7	534
1.7	200	3.8	550
1.8	217	3.9	567
1.9	233	4.0	584
2.0	250	4.1	600
2.1	267	4.2	617
2.2	283	4.3	634
2.3	300	4.4	650
2.4	317	4.5	667
2.5	334		

Table 9: 0-667 psi Transducer Chart

Parameter Configurations

Danfoss CDS803 and CDS303 Parameter Setup			
Parameter	Name	Value to Set	Value Description
1-00	Configuration Mode	0	Speed Open Loop
1-13	Compressor Selection	TBD	Based on Compressor Model connected
3-10	Preset Reference	0	Must remain zero for open loop
3-14	Preset Relative Ref	0	Fixed value added to variable value
3-15	Reference Resource 1	11	Local Bus Reference
3-16	Reference Resource 2	0	No Function
3-17	Reference Resource 3	0	No Function
8-01	Control Site	2	Control word only
8-02	Control Word source	1	FC Port RS-485
8-03	Control Timeout	20	20 second timeout
8-04	Control Word T/O Function	5	Stop and Trip
28-10	Oil System Recovery	0	Disable Built-in Oil Boost
8-30	Protocol	2	Modbus RTU
8-31	Address	1	Modbus Address (1 = default)
8-32	Baud Rate	3	19200 Baud
8-33	Parity / Stop bit	0	Even Parity / 1 Stop bit
Additional CDS803 Parameters			
3-00	Reference Range	0	Min - Max
3-13	Reference Site	1	Remote
0-20	Motor Speed Unit	0	RPM (vs. Hz)
Key			
	blue = user must configure from display		
	yellow = set through communications once communications is established		
	green = default but confirm if not working		

Table 10: Danfoss VFD Parameter Configurations

APPENDIX C: SYSTEM CONFIGURATION

Module and Condenser Configuration

RSMZ Module Configuration

In Prism 2's "Configuration 1 Page", select the radio button for "Check this box for RSMZ modules", select the radio button for "3 Circuit 1 Sub-Cool" or "6 Circuit 2 Sub-Cool", and then select the check box for "RSMZ Has Sub-Cooling Module" if you are using it. See **Figure 12, this page**.

Installed Expansion Boards

Check this box for RSMV modules

Check this box for RSMD modules

Check this box for RSMZ modules

3 Circuit 1 Sub-Cool

6 Circuit 1 Sub-Cool

Pre-Heater Expansion Board

MODGAS-X Board

EM1 Expansion Board

12 Relay Expansion Board

RSMZ Has Sub-Cooling Module

Figure 12: RSMZ Module Configuration

RSMZ Condenser Configuration

Select Prism 2's RSMZ module tab selection. In "Single Condenser Per Module" wiring configuration, the Condenser Signal is wired to AO2 and the Condenser Relay (RLY3) is enabled. See **Figure 13, this page**.

RSMZ Configuration

Condenser Configuration

Standard Condenser Per Module

Single Condenser for A & B

Emergency Shutdown Input

Unit Tonnage

Figure 13: RSMZ Prism 2 Condenser Configuration

RSMZ Technical Guide
G081900 · Rev. A · 210610

AAON Factory Technical Support: 918-382-6450
techsupport@aaon.com

AAON Controls Support: 866-918-1100
Monday through Friday, 7:00 AM to 5:00 PM
Central Standard Time

Controls Support website:
www.aaon.com/controlstechsupport

NOTE: Before calling Technical Support, please have the model and serial number of the unit available.

PARTS: For replacement parts, please contact your local AAON Representative.



2425 South Yukon Ave • Tulsa, OK • 74107-2728
Ph: (918) 583-2266 • Fax: (918) 583-6094
AAON P/N: **G081900**, Rev. A

Printed in the USA • Copyright June 2021 • All Rights Reserved